

# TECHNICAL REGULATIONS GENERAL & FOR ROAD, TRACK & ROLLER RACING

## CONTENTS

<b>Technical Regulation No.1</b>	Application .....	60
<b>Technical Regulation No.2</b>	Definitions .....	60-61
<b>Technical Regulation No.3</b>	Cycles .....	61-62
<b>Technical Regulation No.4</b>	Licences.....	62
<b>Technical Regulation No.5</b>	Age Categories .....	62-63
<b>Technical Regulation No.6</b>	Ability Categories, Event Classification and Licence Points .....	63-66
<b>Technical Regulation No.7</b>	Eligibility to Compete.....	66-67
<b>Technical Regulation No.8</b>	Dress .....	67-68
<b>Technical Regulation No.9</b>	Advertising Agreements .....	68-69
<b>Technical Regulation No.10</b>	Miscellaneous .....	69
<b>Technical Regulation No.11</b>	Banned Substances .....	69
<b>Technical Regulation No.12</b>	Race Infringements and Penalties.....	69-70
<b>Technical Regulation No.13</b>	Prizes.....	70
<b>Technical Regulation No.14</b>	Calendar of Events.....	70-71
<b>Technical Regulation No.15</b>	Permits.....	71
<b>Technical Regulation No.16</b>	Commissaires and Officials .....	71-73
<b>Technical Regulation No.17</b>	National Championships .....	73-75
<b>Technical Regulation No.18</b>	Regional Championships.....	75-76
<b>Technical Regulation No.19</b>	Discipline.....	76
<b>Technical Regulation No.20</b>	Road Racing .....	76-79
<b>Technical Regulation No.21</b>	Stage Races .....	79-80
<b>Technical Regulation No.22</b>	Time Trials .....	80
<b>Technical Regulation No.23</b>	Team Time Trials .....	80-81
<b>Technical Regulation No.24</b>	Track Racing.....	81-85
<b>Technical Regulation No.25</b>	Tracks.....	85
<b>Technical Regulation No.26</b>	Records .....	85-87
<b>Technical Regulation No.27</b>	Roller Racing .....	87
<b>Appendix 1</b>	UCI Equipment Regulations .....	88-91
<b>Appendix 2</b>	Regulations for Road Race Leagues .....	92
<b>Appendix 3</b>	Regulations for the Organisation of Reliability Rides .....	92
<b>Appendix 4</b>	Regulations for the Organisation of Cyclo-Sportive (Cycling for All) Events .....	92-93
<b>Appendix 5</b>	Regulations for "Come and Try" Cycling Sessions.....	93-94
<b>Appendix 6</b>	British Time Trial Championships 2007 .....	94
<b>Appendix 7</b>	Gear Tables .....	95-96

# TECHNICAL REGULATIONS GENERAL & FOR ROAD, TRACK & ROLLER RACING

**Notes:** Also see supplementary Technical Regulations for BMX, Cycle Speedway, Cyclo-Cross and Mountain Bike Racing.

Clubs and Regions wishing to propose alterations to Technical Regulations should note that where the proposition conflicts with any agreement with another body it will be necessary to seek the agreement of that body before the change can come into force.

## 1 APPLICATION

- 1.1 Subject always to the overriding authority of the Memorandum & Articles of Association and Rules of the British Cycling Federation and the provisions of the following:
  - 1.1.1 an agreement dated the 18th May 1985 between the Welsh Cycling Union and the Federation;
  - 1.1.2 an agreement dated the 15th December 1991 between the Federation and the Scottish Cyclists Union;
  - 1.1.3 an agreement dated the 1st January 1970 between the British Schools Cycling Association and the Federation;
- 1.2 Where relevant, these Regulations shall apply to all BMX, Mountain Bike, Road, Circuit, Track or Roller Racing authorised under these Regulations. Supplementary Regulations shall also apply for BMX, Cycle Speedway and Mountain Bike races as indicated in the appropriate section of this Rulebook.
- 1.3 The Technical Regulations apply to both sexes.
- 1.4 The Board of the Federation may, in exercise of the power conferred on it by the Federation's Rules, but subject always to the limitations laid down in this regulation, take any steps it thinks fit in the best interests of the racing authorised under these Regulations. In particular the Board may exercise all or any of the powers specifically given to Regions in these Regulations. Members of the Federation's Board and members of the Federation's staff shall, upon proof of identity, have free access to any track or enclosure used for racing under these Regulations.

## 2 DEFINITIONS

- 2.1 In these Regulations, and in the racing authorised under these Regulations, the following terms shall, where the context so admits, have the following meanings:
  - 2.1.1 **BANNED SUBSTANCES** - any of the categories of substances and doping methods included in the list of banned substances and methods adopted and published by the Union Cycliste Internationale and referred to in the Anti Doping Regulations of the Federation
  - 2.1.2 **CIRCUIT RACE** or **CIRCUIT RACING** or **CLOSED CIRCUIT RACE** - a race or racing on roads in an enclosed area such as a park, motor racing circuit, or disused airfield, and not subject to the provisions of the Cycle Racing on Highways Regulations, 1960.
  - 2.1.3 **CIRCUIT RACE LEAGUE** - a series of more than ten mid-week race meetings confined to members affiliated to the league which provides racing for all categories.
  - 2.1.4 **CLUB RACE** or **CLUB EVENT** - a race or event open only to members of groups of the same club, school, or similar organisation.
  - 2.1.5 **COMPETE** - the act of taking part in any event or attempting any record authorised by these Regulations.

- 2.1.6 **COMPETING UNDER THESE REGULATIONS** - an entrant to any event authorised by these Regulations shall be deemed to be competing under these Regulations from the time that he either first enters a track centre until the end of the meeting or he signs on for a road or circuit race until his licence is returned to him.
- 2.1.7 **CONFINED RACE** or **CONFINED EVENT** - a race or event open only to members of groups of clubs, Associations of Clubs, or similar organisations, affiliated to the Federation.
- 2.1.8 **HANDICAP ROAD RACE** or **HANDICAP ROAD RACING** - a road race or racing taking place on public roads, whether open or closed to members of the public at the time of racing, between two or more approximately equal sized, groups of riders, handicapped by time according to ability category.
- 2.1.9 **INTERNATIONAL EVENT** - an event involving riders from more than four overseas Federations, plus a BCF National Team selection..
- 2.1.10 **MATCH** or **MATCH RACE** - a race between riders on not more than two cycles, or a race between not more than two teams.
- 2.1.11 **OPEN RACE** or **OPEN EVENT** - a race or event open to any licensed affiliated or individual member of the Federation.
- 2.1.12 **POINTS RACE** - a road or track race or racing, scratch or handicap, whereby points are awarded during the race or racing to determine the final placings.
- 2.1.13 **RIDER** - Any competitor taking part in a cycle race or related activity.
- 2.1.14 **ROAD CRITERIUM SERIES** - a series of events (with a minimum of three and a maximum of eight races) in which the award of individual placings or prizes, or both, is determined by the total points accumulated throughout the series. Entries must be for the whole series. Road criterium events must not exceed 100 kilometres.
- 2.1.15 **ROAD RACE** or **ROAD RACING** - a race or racing on public roads whether open or closed to members of the public at the time of racing, but where the race or racing is on a circuit or closed public roads it may be termed a closed circuit criterium all such racing must conform to the provisions of the Cycle Racing on Highways Regulations 1960 (Statutory Instrument No. 250 of 1960), the Amendment of 1980 (Statutory Instrument No. 1185), the Amendment of 1988 (Statutory Instrument No. 215) (the Regulations) and the Amendment of 1995 (Statutory Instrument No. 3241 of 1995)
- 2.1.16 **ROAD RACE LEAGUE** - a collection of Clubs associated together to promote road races for their members.
- 2.1.17 **T.R.** - Abbreviation of Technical Regulation(s)
- 2.1.18 **TRACK** - a symmetrical circuit (preferably under 500 metres) constructed for cycle racing and generally having banked corners. The surface may be concrete, asphalt, wood, shale, cinders or grass, the dimensions being in accordance with the current recommendations of the Federation. The racing will be in an anti-clockwise direction.
- 2.1.19 **TRACK RACE** or **TRACK RACING** or **TRACK MEETING** - all forms of cycle racing on facilities as referred to in T.R. 2.1.18.

2.1.20 TRACK LEAGUE - a series of 6 or more race meetings confined to members affiliated to the league which provides racing for all categories.

### 3 CYCLES

3.1 The following cycles only are eligible for races held under these Regulations, and in every case the whole motive power must be that of the rider or riders:

3.1.1 For Bicycle Races. Any two-wheeled one-track cycle carrying one rider.

3.1.2 For Tandem Bicycle Races. Any two-wheeled one-track cycle carrying two riders seated one directly behind the other.

3.1.3 For Tricycle Races. Any three-wheeled cycle, two or more tracked, carrying one rider, the width of the track made by its wheels being at least 18 inches, and having all wheels on the ground.

3.1.4 For Tandem Tricycle Races. Any cycle fulfilling the conditions of T.R. 3.1.3. with the exception that it carries two riders, seated one directly behind the other.

3.1.5 For Multicycle Races. Any cycle carrying three or more riders, all seated one directly behind another.

3.1.6 For Handcycling Races. Disabled users of hand and arm propelled tricycles (referred to as "Handcycles") may compete on machines as approved by the BCF Technical Commission and defined in T.R. 3.5

3.2.1 All cycles shall have their wheels securely fastened to their frames, with their tyres, if of tubular construction, secured firmly by tubular cement or similar means.

3.2.2 In motor-cycle paced events both wheels of the pace following cycle must have the tyre bound on to the rim by two continuous bands, divided by the tread and passing under the rim and stuck one to the other. The bands must also be stuck to the walls of the tyre and the rim. Pedals shall not overlap the front wheels.

3.2.3 Handlebar ends shall be plugged, not merely covered by tape, and other projections shall be protected as far as possible.

3.2.4 Cycles used for track racing shall not be fitted with freewheels, quick release wheels, wing nuts, brakes or similar accessories, except by permission of the Board or the Region concerned.

3.2.4.1 Tyres used for grass track racing must have treads suitable for such racing.

3.2.5 Cycles used for road or circuit racing shall be fitted with a freewheel and two independent brakes in good working order, with their brake levers securely fastened to the handlebars.

3.2.6 In all track events Youth B and C riders shall conform to the following requirements, except where dispensation under T.R. 3.3.3 is supplied -  
Wheels shall have a maximum rim depth of 35mm, have minimum of 16 and a Maximum of 40 spokes. Spokes can be round, flattened or oval but must not exceed 10mm in width.  
Machines with dropped handlebars shall be used. Tri-bars, arm extensions and/or arm pads shall be prohibited

3.2.7 Pumps, spare tyres and race computers must be securely fastened. All other equipment not essential for racing purposes must be removed.

3.2.8 In all other respects cycles shall be in accordance with the requirements as laid down from time to time by the Board.

3.2.9 Where a rider is found to be using a machine which in the opinion of the Chief Commissaire presents a danger to himself or others he shall be withdrawn from the event and reported to the Region issuing the permit.

3.2.10 It is the responsibility of the competitor and/or the parent or guardian in the case of under 18s, to ensure that for every race held under these regulations his cycle is in a safe condition.

### 3.3 Gear Restrictions

3.3.1 In all road events (other than events promoted in accordance with T.R. 7.12) juniors shall be restricted to a maximum gear such that the distance covered per crank revolution is 7.93 metres. The gear restriction shall not apply to seniors.

3.3.2 In all events other than under the provisions of 3.3.3 below, Youth category riders shall be restricted to maximum gears as shown in the following table.

#### YOUTH CATEGORY GEAR RESTRICTIONS

CATEGORY	ROAD RACING	TRACK RACING	ROLLER RACING
YOUTH A	6.93 metres	6.93 metres	7.93 metres
YOUTH B	6.45 metres	6.45 metres	7.40 metres
YOUTH C	6.05 metres	6.05 metres	6.94 metres
YOUTH D	5.40 metres for all events.		
YOUTH E	5.10 metres for all events.		

3.3.3 For track and roller racing events where a Youth A, B or C rider has received dispensation from BCHQ to compete against riders of an older category, then that rider shall be restricted in gearing to that of the older category.

3.4 Other than as set out in this Regulation, the Board requires cycles to comply with UCI Regulations covering bicycles. **SEE APPENDIX 1 OF THESE TECHNICAL REGULATIONS**

### 3.5 Handcycles

3.5.1 Handcycling is for riders who normally require a wheelchair for general mobility and are not able to use a conventional bicycle because of severe lower limb disability. For competition, riders must satisfy the specific disability requirements for handcycling, as currently specified by the International Paralympic Committee. A purpose built handcycle, or a wheelchair with a handcycle attachment, should conform to the following specification.

3.5.1.1 An upright, or semi-recumbent, tricycle with an open frame of tubular construction and a safe and effective method of steering.

3.5.1.2 Motive power must be from the hands, arms and upper body only, through a conventional cycle drive train, of crank arms, chainwheels, chain and gears, with handgrips replacing foot pedals. Cranks need not be at 180 degrees to each other.

3.5.1.3 Wheels and tyres must be conventional cycle components, with modified hub attachment if necessary and a maximum tyre size of 700c.

3.5.1.4 Two independent brakes must be fitted. It is recommended that one or both brakes can be locked to act as a parking brake.

3.5.1.5 The final drive will normally be to the single front wheel and the largest chainwheel must have a guard securely fitted to protect the rider.

3.5.1.6 Maximum frame tube dimension, irrespective of tube material, or profile, to be 80mm. Any fillets, or ribs, inserted at joints between tubes, must be for strengthening purposes only. Non-functional, aerodynamic devices are not permitted for competition.

3.5.1.7 Leg and foot rests must be fitted as necessary, with a secure means of protecting static lower limbs from all moving parts.

- 3.5.1.8 The rider must be seated in a relatively upright position, with bodyweight supported through the seat. Although a backrest is permitted, the riding position must not be reclined backwards so that the backrest provides the primary upper body support.

## 4 LICENCES

- 4.1.1 Every entrant in a race held under these Regulations (other than as provided in Bye-Law 3.5, T.R. 7.12, an entrant in Roller Racing held in Federation Territory or a member of an overseas Federation) and those officials detailed in these Regulations must be members of the Federation.
- 4.1.2 Licences shall be issued in accordance with the current Regulations of the Union Cycliste Internationale
- 4.1.3 The member must have obtained a licence from the Federation before the race in question other than for time trials held under Federation Regulations.
- 4.2 The following licences shall be issued by the Federation
- 4.2.1 Racing
- 4.2.2 Team Manager
- 4.2.3 Commissaire
- 4.2.4 Time Keeper
- 4.2.5 Motor Pacer
- 4.2.6 Masseur
- 4.2.7 Anti Doping Inspector
- 4.2.8 Doctor
- 4.2.9 Mechanic
- 4.2.10 Handicapper
- 4.3.1 The issue of Racing Licences is governed by T.R. 4.4.
- 4.3.2 All other licences are issued under conditions laid down from time to time by the Board.
- 4.4 Racing Licences**
- 4.4.1 Racing Licences issued by virtue of Bye-Law 3.5 shall be valid for all racing disciplines
- 4.4.2 A licence other than a temporary single or Provisional event licence shall expire on 31st December of the year for which it is issued.
- 4.4.3 Where a license holder is under suspension extending into a period requiring a new licence, no new licence shall be issued until the period of suspension has expired.
- 4.4.4 A licence may be withheld or withdrawn on medical grounds and licence holders must advise the Chief Executive of any disability or medical condition, physical or mental, which could affect their ability to ride safely as a racing cyclist. The Chief Executive may refer such matters to the Board or the Medical Commission.
- 4.5.1 The racing licence will carry the separate discipline, age and ability categories of the rider.
- 4.5.2 Should the licence holder change any category during any year, then a new licence will be issued free of charge showing the new category.
- 4.5.3 Riders upgraded during the year will start the following season with their new category, where appropriate, even if they have obtained no points in their new category.
- 4.5.4 Each rider will start with zero points at the beginning of each year (i.e. no points will be carried forward from the previous year).

- 4.6 Licences will be required to carry a photograph showing a good likeness of the holder and it is the responsibility of the holder to affix such a photograph.

## 4.7 Temporary Licences

- 4.7.1 No such temporary licence shall permit a rider to ride in any other category than if he had taken out an annual licence.
- 4.7.2 Any temporary licence holder reported to have infringed the Bye-Laws or Technical Regulations of the Federation may be the subject of disciplinary action as laid down in the Regulations whether or not at the time of the action he was a member of the Federation.
- 4.7.3 All temporary licence holders under 18 years of age, shall submit a parental consent form and all riders, regardless of age, shall pay any entry fee and levy in addition to the licence fee. The completed signing on sheets shall retained by the Race Organiser who shall forward them with the levies to the Region Treasurer.
- 4.7.4 Only annual licence holders may compete in Regional Championships plus events falling under Technical Regulation 15.2 except where specific competition regulations specify otherwise. Temporary licences are not acceptable for these events.

## 5 AGE CATEGORIES

Licences, which shall be valid for all disciplines, shall be issued as follows:

### 5.1 Youth

- 5.1.1 **Youth E** - Under 8 - Until 31 December in year of 8th birthday.
- 5.1.2 **Youth D** - Under 10 – From 1 January in year of 9th Birthday until 31 December in year of 10th birthday.
- 5.1.3 **Youth C** - Under 12 -. From 1 January in year of 11th Birthday until 31 December in year of 12th birthday
- 5.1.4 **Youth B** - Under 14 - From 1 January in year of 13th Birthday until 31 December in year of 14th birthday
- 5.1.5 **Youth A** - Under 16 - From 1 January in year of 15th Birthday until 31 December in year of 16th birthday. On reaching his 16th birthday a rider may apply for a Junior competition licence in order to be permitted to compete on the open road. On taking up this option he may no longer compete as a Youth rider.

#### **Note:**

*Whilst the above categories may be grouped together in events, promoters should be conscious of the range of abilities of riders within the youth categories. This can be helped by running events for different age groups, different sizes, similar ability, by forming suitable handicaps or by offering separate awards for different groups. Girls are permitted to compete in events open to, and for awards available to, those Boys of the next youngest age category at the discretion of the chief Commissaire. In such situations, such Girls must restrict themselves to that gear restriction as per the Boy's category. Two or three shorter races on an omnium basis may also be more suitable than one longer race.*

### 5.2 Junior

- 5.2.1 Junior - To any male or female junior member of the Federation.
- 5.2.2 A member who has not reached his 18th birthday may not compete without having provided the consent of their parent or guardian in the form as prescribed from time to time by the Board.
- 5.2.3 Applicants for an annual licence must send such a Parental Consent Form, duly completed and signed, to Federation Headquarters and any licence issued is only valid if such a form has been received. At the time of application for an annual licence the parent's or guardian's signature must be witnessed by an official of the member's club or other responsible adult.

## SYNOPSIS OF AGE CATEGORIES FOR 2008

Category	Qualification	
Youth E Under 8	born in 2000 or later	Until 31st December of year in which 8th birthday falls
Youth D Under 10	born in 1998 or 1999	From 1st Jan of year in which 9th birthday falls to 31st December of year in which 10th birthday falls
Youth C Under 12	born in 1996 or 1997	From 1st Jan of year in which 11th birthday falls to 31st December of year in which 12th birthday falls
Youth B Under 14	born in 1994 or 1995	From 1st Jan of year in which 13th birthday falls to 31st December of year in which 14th birthday falls (or upgraded from Youth C).
Youth A Under 16	born in 1992 or 1993	From 1st Jan of year in which 15th birthday falls to 31st December of year in which 16th birthday falls (or upgraded from Youth B).
Junior	16 yrs old or born in 1990 or 1991	From 1st Jan of year in which 17th birthday falls to 31st December of year in which 18th birthday falls.
Under 23	born in 1986, 1987, 1988 or 1989	From 1st Jan of year in which 19th birthday falls to 31st December of year in which 22nd birthday falls.
Over 23	born in 1985 or earlier	From 1st Jan of year in which 23rd birthday falls.
Women	born in 1989 or earlier	From 1st Jan of year in which 19th birthday falls.
Master A 30 – 34	born in 1974, 1975, 1976, 1977 or 1978	From 1st Jan of year in which 30th birthday falls to 31st December of year in which 34th birthday falls.
Master B 35 – 39	born in 1969, 1970, 1971, 1972 or 1973	From 1st Jan of year in which 35th birthday falls to 31st December of year in which 39th birthday falls.
Master C 40 – 44	born in 1964, 1965, 1966, 1967 or 1968	From 1st Jan of year in which 40th birthday falls to 31st December of year in which 44th birthday falls.
Master D 45 – 49	born in 1959, 1960, 1961, 1962 or 1963	From 1st Jan of year in which 45th birthday falls to 31st December of year in which 49th birthday falls.
Master E 50 – 54	born in 1954, 1955, 1956, 1957 or 1958	From 1st Jan of year in which 50th birthday falls to 31st December of year in which 54th birthday falls.
Master F 55 – 59	born in 1949, 1950, 1951, 1952 or 1953	From 1st Jan of year in which 55th birthday falls to 31st December of year in which 59th birthday falls.
Master G 60 – 64	born in 1944, 1945, 1946, 1947 or 1948	From 1st Jan of year in which 60th birthday falls to 31st December of year in which 64th birthday falls.
Master H 65 – 69	born in 1939, 1940, 1941, 1942 or 1943	From 1st Jan of year in which 65th birthday falls to 31st December of year in which 69th birthday falls.
Master I 70 +	born in 1938 or earlier	From 1st Jan of year in which 70th birthday falls.

**Note:** For cyclo-cross age categories, refer to the specific cyclo-cross regulations.

### 5.3 Senior

5.3.1 Senior - To any member of the Federation from the 1st January of the year of their 19th birthday.

5.3.2 All licences issued to seniors will be further categorised by age:

5.3.3 Under 23 To any male member from 1st January of the year of their 19th birthday until 31st December of the year of their 22nd birthday. A rider registered as a member of a U.C.I. Pro-Tour or Professional Continental Trade Team shall be ineligible to compete in the Under 23 category on the road.

5.3.4 Over 23 - from 1st January of the year of their 23rd birthday.

5.3.5 **Master** - Any member from the 1st January of the year of his 30th birthday who is not a member of a U.C.I. Pro-Tour or Professional Continental Trade Team in the discipline of that event. Master's age groupings are Group A: 30-34, Group B: 35-39, Group C: 40-44, Group D: 45-49, Group E: 50-54, Group F: 55-59, Group G: 60-64, Group H: 65-69 and Group I : 70 +

**Note:** Riders aged over 30 are advised that this definition of a Master only applies to events run under the Technical Regulations of British Cycling Federation

5.3.6 Disabled - To any member of the Federation of any age who satisfies the minimum disability requirements as currently specified by the International Paralympic Committee. Classes of disability include locomotor, amputee, deafness, visual impairment, cerebral palsy and learning disabilities.

5.4.1 Riders eligible for the Masters and Disabled categories may take part in events organised solely for those categories.

5.4.2 While competing in such events the riders shall be eligible for the groupings as indicated.

5.4.3 All age groupings are defined as being on the 1st January of the year of the appropriate birthday. For cyclo-cross age definitions refer to the cyclo-cross specific technical regulations.

## 6 ABILITY CATEGORIES, EVENT CLASSIFICATION AND LICENCE POINTS

6.1 All junior and senior licence holders, male or female, irrespective of the age category into which they fall will be categorised by their ability. Riders of the same ability category will continue to compete together in races irrespective of their age category, except in the case of events organised for specific age related groups.

6.2 Ability categories will be as follows:

6.2.1 **4th Category** - new junior or senior licence holder. As a guide this will equate to Fun Category in Mountain Biking.

6.2.2 **3rd Category** - To any junior or senior licence holder who has gained at least 10 but less than 40 points whilst holding a 4th category licence. As a guide this will equate to Sport Category in Mountain Biking. Riders are not downgraded to 4th category once a 3rd category licence has been achieved.

6.2.3 **2nd Category** - To any junior or senior licence holder who has gained 40 points during any one season whilst holding a 3rd category licence. As a guide this will equate to Expert Category in Mountain Biking.

6.2.3.1 To retain a 2nd category licence for the following season, a rider must obtain at least 25 points in events open to that category of rider.

6.2.4 **1st Category** - To any junior or senior licence holder who has gained 200 points during any one season whilst holding a 2nd category licence. As a guide this will equate to most Elite Category riders in Mountain Biking with the exception of those in the top 10 of the BC National Rankings.

- 6.2.4.1 To retain a 1st category licence for the following season, a rider must obtain at least 100 points in events open to that category of rider.
- 6.2.5 **Elite Category** - To any member who:
- 6.2.5.1 is a registered member of a U.C.I. registered trade team subject to such members having met the appropriate proven ability standard.
- 6.2.5.2 has gained 300 points during the previous season whilst holding an elite or 1st category licence,
- 6.2.5.3 at the 31st December of the previous year was listed in the top 10 riders in the Senior Men's National Cross Country Mountain Bike Ranking System,
- 6.2.6 **Junior Riders** – On reaching the Junior age category, existing licence holders will be awarded initial ability categories as follows:
- 6.2.6.1 4th Category – any rider who has gained no Youth licence points in the previous year.
- 6.2.6.2 3rd Category – any rider who has gained Youth licence points in the previous year.
- 6.2.6.3 2nd Category male – Any rider who has achieved:  
 Top 15 in the Youth A Boys in the previous year's National Circuit Race Series  
 Top 10 in the Youth A Boys in the previous year's Track Omnium Series  
 Top 3 in Any in the previous year's Road/Track Youth A Boys National Championship  
 Top 10 in Youth A Boys National Rankings in the previous season
- 6.2.6.4 2nd Category female – Any rider who has achieved:  
 Top 5 in the Youth A Girls in the previous year's National Circuit Race Series  
 Top 10 in the Youth A Girls in the previous year's Track Omnium Series  
 Top 3 in any in the previous year's Road/Track Youth A Girls National Championship  
 Top 5 in Youth A Girls National Rankings in the previous season
- 6.2.6.5 Junior riders will not be eligible for elite licences
- 6.2.7 **Dispensation**
- 6.2.7.1 Masters over the age 40 having gained an elite category licence may apply to Headquarters for a first category licence if that is their wish.
- 6.2.7.2 At the discretion or instruction of the Board, a rider who, although not meeting the criteria set out in T.R. 6.2.1 to T.R. 6.2.6, may be issued with a licence of a different category.
- 6.2.7.3 Category B and C Youth riders who gain 15 licence category points in any one year may apply to the Board for dispensation to compete in events restricted to the next higher age category. Youth C Riders shall not be granted a dispensation to ride as a Youth A.
- 6.2.7.4 Category A Youth riders who gain 15 licence category points in any one year, or who have attained a top 10 place in the previous year's National Youth A rankings may apply to the Board for dispensation to compete in events against riders of any older category in closed road and track meetings. This dispensation does not apply to National A events. For national and regional championships the dispensation is limited to events restricted to the next highest age category, i.e. junior.
- 6.2.7.5 Category A, B and C Youth riders may apply to the Board for dispensation to compete in events against riders of any older category in track league meetings.
- 6.2.7.6 Riders receiving dispensation under T.R. 6.2.7.3 to 6.2.7.5 shall be issued with an authorisation card and this must be produced by the rider when signing on at events to which the dispensation applies
- 6.3 **Event Classification**
- 6.3.1 Road and Circuit events, other than those exclusively for Youth riders, shall be classified as follows:
- 6.3.1.1 **National A** – open to Senior male Elite, 1st and 2nd category riders. National A closed road circuit races shall also be open to 1st and 2nd category Junior riders.
- 6.3.1.1.1 Only one National A event shall be held on the same day.
- 6.3.1.1.2 The minimum distance for a single day road race shall be 130 km if terrain is demanding, rising to a maximum of 180 km on flatter terrain.
- 6.3.1.1.3 The minimum distance for a road stage of a stage race shall be 80 km.
- 6.3.1.1.4 The minimum time for a circuit race shall be 60 minutes, and the maximum 90 minutes.
- 6.3.1.1.5 The main prize list shall be a minimum of £2,000. Prize money shall be paid to riders placed at least 1st to 20th, in accordance with the following structure:
- |                  |                   |                |
|------------------|-------------------|----------------|
| 1st - 20%        | 2nd - 15%         | 3rd - 12%      |
| 4th - 8.5%       | 5th - 7%          | 6th - 6%       |
| 7th - 5%         | 8th - 4%          | 9th - 3.5%     |
| 10th - 3%        | 11th - 2.5%       | 12th-14th - 2% |
| 15th-17th - 1.5% | 18th to 20th - 1% |                |
- 6.3.1.2 **National B** – open to Senior male Elite, 1st, 2nd and 3rd category riders, final year Junior male 1st, 2nd and 3rd category riders and Senior female Elite, 1st and 2nd category riders. Where the minimum distance for a road race is not achieved, the race shall be open to all Junior male 1st, 2nd and 3rd category riders and all Junior female 1st and 2nd category riders.
- 6.3.1.2.1 The minimum distance for a road race shall be 120 km on demanding terrain.
- 6.3.1.2.2 The minimum time for a circuit race shall be 60 minutes.
- 6.3.1.3 **Regional A** – open to Senior and Junior male 2nd, 3rd and 4th category riders and Senior and Junior female riders of all categories
- 6.3.1.3.1 The minimum distance for a road race shall be 80 km.
- 6.3.1.3.2 The minimum time for a circuit race shall be 50 minutes.
- 6.3.1.4 **Regional B** – open to Senior and Junior male 3rd and 4th category riders and Senior and Junior female riders of all categories
- 6.3.1.4.1 The maximum distance for a road race shall be 90 km.
- 6.3.1.4.2 The minimum time for a circuit race shall be 40 minutes.
- 6.3.1.5 **Regional C+ and Regional C** – open to Senior and Junior riders of all categories, to be run as a handicap event, or other appropriate format. Such events may also be restricted to 4th Category riders only.
- 6.3.1.5.1 The minimum time shall be 60 minutes, and the maximum 90 minutes. Where the circuit is too small to allow for a handicap event which meets the minimum time requirement, the organiser may choose to use an alternative format, provided that the chosen format reasonably caters for the widest possible range of ability.

6.3.1.6 **Go Race** – open to 4th category riders, British Cycling members without racing licences and non-members. Youth A & B riders without any licence ranking points in the current year may also compete in these events. Such events must be no more than 30 minutes in duration and off the open highway.

6.3.1.6.1 The maximum time for a Go-Race event shall be 90 minutes.

6.3.2 Time Trials shall be run as Regional C+ or Regional C events.

#### 6.4 Licence Points

6.4.1 Licence points are awarded as shown in the table below:

Points Band	1	2	3	4	5
Position	Nat A Road	Nat B Road Nat A Circuit	Reg A Road Nat B Circuit	Reg B Road Reg A Circuit	Reg C + Reg B Circuit
1	100	60	30	15	10
2	85	52	25	12	8
3	75	45	21	10	7
4	66	40	17	8	6
5	58	35	14	6	5
6	51	31	12	5	4
7	45	27	10	4	3
8	39	23	8	3	2
9	34	20	7	2	1
10	29	17	6	1	1
11	25	15	5		
12	21	13	4		
13	18	11	3		
14	15	9	2		
15	12	7	1		
16	10	6			
17	8	5			
18	6	3			
19	4	2			
20	2	1			

6.4.2 Regional C and Go Race events do not qualify for licence points.

6.4.3 For stage races, points shall be awarded for final standings in the general classification.

6.4.4 For specific road and circuit events, the following points bands shall apply :

	Points Band
National A Stage Race: Individual Stage (including Time Trials)	3
National B and C Stage Races: Individual Stage (including Time Trials)	4
Regional Stage Races: Individual Stage (including Time Trials)	5
National Championship or National Series event for Women	2
Other event open only to Women	3
National Championship or National Series event for Juniors	2
Other event open only to Juniors	3
National Championship or National Series event for Masters	3
Other event open only to Masters	4

6.4.5 Where the minimum road race distance, as defined in T.R. 6.3, is not achieved, the next lower points band allocation is utilised.

6.4.6 For track racing, only endurance scratch events, including pursuits and time trials of not less than 3 km, and the final standings in track leagues, shall qualify for licence points, except for events restricted to Youth riders. The following points bands shall apply, but only the first six shall receive points:

	Points Band
Standard event	5
National Championship or National Series event	3
Final standings in Track Leagues	4

6.4.7 For any closed road circuit event, open track event including the overall result (but not the constituent events) of any Omnium Competition but excluding course des primes events) restricted to Youth category riders, the following points shall apply:

Standard event:

First - 3 points Second - 2 points Third - 1 point

National series event:

First- 6 points Second - 4 points Third - 2 points

Track League (overall) and National Championships:

First - 9 points Second - 6 points Third - 3 points

Where a Youth race includes riders of both genders then the top three placed riders from each gender shall receive the appropriate national licence ranking points.

6.4.8 In the case of equalities of placing, the relevant combined points shall be divided amongst the riders concerned equally and rounded up to the nearest whole number.

6.4.9 A rider who has obtained sufficient points for upgrading, but who has entered an event for which the closing date has passed under his current category may compete in that event but will not be eligible for any upgrading points.

6.4.10 Where an event is restricted to specific categories of senior rider it shall only be open to similar categories of Masters.

6.4.11 Senior riders selected for international duty shall be issued with an elite category licence in the following season. Junior riders shall receive a first category licence.

6.4.12 In the case of events restricted to members of the same club no points will be awarded

**Note:** Surplus points remaining after an upgrade shall be carried forward in the new category (e.g. A third category rider has 33 points to date. In the next race the rider gains 10 points to reach a total of 43. 40 points are lost through upgrading and the remaining 3 are carried forward to be credited towards the rider's second category licence).

#### 6.5 National and Regional Rankings

6.5.1 Licence points gained in National events will be utilised to determine the following National rankings:

6.5.1.1 National Individual Rankings. A ranked list of all riders will be determined by total points scored in National events, and produced for Elite, 1<sup>st</sup>, 2<sup>nd</sup> and 3<sup>rd</sup> category riders.

6.5.1.2 National Club /Team Rankings. A ranked list of clubs / teams will be determined by total points scored in National events, with a maximum of 3 scoring riders per Club / Team in any one event.

6.5.1.3 National Region Rankings. A ranked list of all Regions will be determined by total points scored in National events, with a maximum of three scoring riders in any one event.

- 6.5.1.4 Women's Rankings. Separate National Individual, Club / Team and Region rankings will also be produced for women. Such rankings will be determined by total points scored in all events, and in the case of Individual rankings, will be produced for all ability categories.
- 6.5.1.5 National Youth Rankings. A ranked list of all riders will be determined by total points scored in Youth events, and produced for each Youth age category, male and female.
- 6.5.2 Licence points gained in Regional events will be utilised to determine the following Regional rankings:
- 6.5.2.1 Regional Individual Rankings. A ranked list of all riders will be determined by total points scored in Regional events, and produced for 2<sup>nd</sup>, 3<sup>rd</sup> and 4<sup>th</sup> category riders.
- 6.5.2.2 Regional Club /Team Rankings. A ranked list of clubs / teams will be determined by total points scored in Regional events, with a maximum of 3 scoring riders per club / team in any one event. Points will only be scored for a club / team if the event is held in the Region in which the club / team is registered.
- 6.5.3 Points scored by Elite and 1st category riders in Regional C+ events will count towards National rankings.
- 6.5.4 Points scored by 2<sup>nd</sup>, 3<sup>rd</sup> and 4<sup>th</sup> category riders in Regional C+ events will count towards Regional rankings
- 6.5.5 Points scored by 2<sup>nd</sup> and 3<sup>rd</sup> category riders in National events will count towards both National and Regional rankings
- 6.5.6 For the purpose of National Region Rankings and Regional Individual Rankings, points will be awarded on the basis of the rider's region of residence, and not of his club / team affiliation. Those residing at a non-permanent address, e.g. full-time students and members of the armed forces, may opt to record their points for the region of either their temporary or permanent address.
- 7 ELIGIBILITY TO COMPETE**
- 7.1 A rider not a British subject is ineligible to compete unless he holds the licence of a Federation recognised by the Union Cycliste Internationale.
- 7.2.1 A competitor must not enter, nor accept an invitation to compete, in more than one event (whether under the Regulations of the Federation or Cycling Time Trials) on the same day except when his entry or acceptance for one event has been withdrawn before the closing date for that event, or it is possible and reasonable for him to start and finish in both events.
- 7.2.2 Where a rider fails to compete in an event under these Regulations after previously having accepted an offer of expenses or an invitation to compete in the event, such failure shall be a breach of these Regulations, unless it was caused by illness or other reason satisfactory to the organiser of the event.
- 7.3 Whenever a resident outside the United Kingdom, Isle of Man and the Channel Islands and holding a licence issued by the U.C.I. or by an overseas Federation is invited and agrees to compete in an event which carries UCI ranking points in Federation territory the organiser shall notify full details of the invitation to the Competition Director of the Federation.
- 7.4 An individual who is not normally resident in the United Kingdom, the Isle of Man or the Channel Islands and who is not a member of a club affiliated to the Federation may compete in events promoted under the Regulations of the Federation provided that he is a member of a club which is affiliated to a national governing body which is itself affiliated to the U.C.I. and holds a current racing licence issued by such governing body, and is authorised by it to compete in the U.K. Any such individual shall compete in the name of his home club unless he is a member of a national or regional representative team.
- 7.5.1 Where a rider is invited by the Board to represent the Federation the invitation shall take precedence over any entry he may already have made to another event, and the rider shall so inform the organiser.
- 7.5.2 Where a rider has withdrawn from an event due to accepting an Board selection, the organiser may accept a substitute entry from the rider's club or representative team provided the substitute rider can enter without being in breach of T.R. 7.2.1.
- 7.5.3 Where National teams are selected to ride in a British event the selection must be made not less than seven days before the closing date for the event.
- 7.6.1 No team or individual may represent a Region, an Area, a County, England or Great Britain unless chosen by the appropriate Region or Regions in the first three cases or the Board in the two latter cases.
- 7.6.2 No composite team may compete abroad without having obtained Federation approval. Such applications must be made in writing to the Board at least three weeks in advance of the event concerned.
- 7.7 No Federation member shall in any way compete or interfere in an event when not an eligible competitor.
- 7.8.1 Every competitor shall produce his current racing licence before he is issued with his competitor's number or allowed to compete.
- 7.8.2 Whilst he is competing the licence shall be retained in the custody of an official appointed for the purpose by the event organiser.
- 7.8.3 For all events, only competitors whose names appear on the list of competitors and/or signing-on sheet shall be allowed to start.
- 7.8.4 No organiser shall enter or advertise as a competitor any rider who has not submitted an entry or acceptance.
- 7.8.5 The current holder of a Championship or Trophy shall be given free entry to defend his title or trophy
- 7.9.1 A rider may only be a first claim member of one club for all forms of road and track competition.
- 7.9.2 A competitor in an open event may only enter and compete in the name of his first claim club, as an individual member, or as a member of a National, Region or Association representative team.
- 7.9.3 When changing his first claim club a member must immediately send his Federation membership certificate to Federation Headquarters for the change to be made. The membership certificate will be forwarded to the Secretary of the new Club.
- 7.9.4 A rider may apply to include more than one club or team on his competition licence where he wishes to ride for different clubs or teams in different disciplines. All such clubs or teams must be affiliated to British Cycling or another UCI affiliated Federation.
- 7.9.5 Competitors who are regular members of HM Armed Forces are also permitted, when chosen by their parent service or by the Combined Services Cycling Association, to represent those organisations in open events.
- 7.9.6 Competitors who are full-time students at University or other establishment of further education, are also permitted to represent the affiliated Club of that establishment during term time.
- 7.10.1 All entries shall be made and all races ridden in the real name of the competitor
- 7.10.2 The submission of an entry form shall be taken to mean that the particulars contained on the form are accurate and complete;

## 7.11 Youth Events

Youth category riders may only compete amongst themselves except in the following circumstances:

7.11.1 Where dispensation is issued under the provisions of T.R. 6.2.7.4 or 6.2.7.5, or under the provision of T.R. 6.3.1.6.

7.11.2 Races open to male Youth A category riders will also be open to 2nd, 3rd & 4th category female riders of any age.

## 7.12 Non Member Events

Affiliated clubs may promote events for non-members.

7.12.1 These events must be on closed circuits, closed roads, or on the track.

7.12.2 Applications shall be made and a permit issued in accordance with the appropriate Regulations.

7.12.3 Competitors in these events need not comply with T.R. 8.1.1, 8.1.2. and 8.1.3. except that protective headgear as laid down in T.R. 8.6 must be worn.

7.12.4 Competitors in these events need not comply with the gear restrictions contained in T.R. 3.3.1 and 3.3.2.

7.12.5 For these events an insurance fee as defined in Bye Law 3.8.7 shall be charged in addition to the entry fee set by the organiser.

7.12.6 Entrants for these events shall complete an entry within the signing on sheet and this shall be retained by the event organiser together with a completed parental consent form for any person who is under 18 years of age on the day of the event.

7.12.7 The signing on sheet, parental consent forms and the insurance fees shall be forwarded to the Region Treasurer no later than 7 days after the event.

## 8 DRESS

8.1.1 When competing under these Regulations competitors (other than as provided in T.R. 7.12 and 8.1.8.) must be completely clothed from neck to no shorter than mid thigh in a costume which consists of a sleeved jersey or vest and racing shorts, or tights or a one-piece costume resembling this.

8.1.2 When competing under these Regulations riders (other than as provided in T.R. 8.1.8 and 8.1.9) shall wear Club or Region registered design and colours, as is appropriate.

8.1.3 The racing costume of a competitor must be free of all lettering except for the name of his club or representative team and as permitted by T.R. 9.

8.1.4 Registered club clothing may carry contact details such as E-mail or Web Site addresses. Where within such an address there is a reference to a commercial enterprise, a separate advertising agreement shall be registered and sponsorship registration fee shall be paid where one does not already exist.

8.1.5 No competitor shall wear a political sign or badge on his racing costume.

8.1.6 Any form of eye protection or spectacles worn must be of a non-splinterable material.

8.1.7 No competitor who is dirty or untidily dressed shall be permitted to start.

8.1.8 Foreign competitors shall be permitted to wear any jersey which complies with their own Federation's requirements.

8.1.9 In Road and Track events, Youth, Fourth and Provisional category licence holders and BC non licence holders will be allowed to wear any suitable clothing whilst competing in events under the Technical Regulations of the Federation, including that bearing registered or unregistered advertising except in the case of National Championships when they

must comply with T.R. 8.1.1 to 8.1.6. However protective headgear must be worn in accordance with T.R. 8.6.

## 8.2 Registration of Clothing

8.2.1 Affiliated Clubs, Trade Teams and Individual Members shall register the design and colour of their racing costume with Headquarters. Upon approval Headquarters shall notify the appropriate Region of the design and colour.

8.2.2 Headquarters shall keep a Register of Colours and shall have power to require clubs with similar colours to alter the designs to prevent duplication.

8.2.3 A works house or recreation club wishing to place its club name on racing clothing shall register an advertising agreement.

8.2.4 Each Region shall register the design and colours of its racing costume with BC Headquarters.

8.2.5 The Board shall have power to require Regions with similar colours to alter the design to prevent duplication.

## 8.3 Representative & Championship Jerseys

8.3.1 Riders may wear the National representative jersey only when competing as members of a team selected by the Board to represent Great Britain or England as the case may be.

8.3.2 Only the current holder of a World, National or Region Championship shall wear the jersey appropriate to those Championships and then only when competing in the type of racing at which he is Champion.

## 8.4 National Championship Jerseys

8.4.1 The design of a National Championship jersey for men and women shall be white with 5 cm wide red, white and blue bands around the chest, the red band being uppermost.

8.4.2 The design of a National Championship jersey for Masters shall be blue with 5 cm wide red, white and blue bands around the chest, the red band being uppermost

8.4.3 The National Championship jersey must be worn by the holder when competing in events of the relevant discipline, unless eligible to wear the jersey of World Champion or event/series leader. Duration of the event is taken from signing on to the completion of any presentation ceremonies.

8.4.4 The following advertising inscriptions are permitted on National Championships jerseys:

8.4.4.1 On the front and back - within a rectangle with a maximum height of 10 cm.

8.4.4.2 On each side - a lateral band with a maximum height of 9 cm.

8.4.4.3 On quarter sleeves - one line with a maximum height of 5 cm.

8.4.4.4 The garment manufacturer's mark may also appear once and within a maximum area of 25 sq. cm.

8.4.4.5 The only inscription which is permitted on the National Championship jersey presented to a rider on the podium immediately after a National Championship is that of the garment manufacturer which may appear once and within a maximum area of 25 sq. cm.

## 8.5 Race Numbers

8.5.1 The wearing of numbers shall be compulsory on track and road.

8.5.2 The number(s) shall be securely attached and not be folded, obscured or mutilated in any way.

8.5.3 With the exception of time trials, motor pace, tandem events and pursuits where a single number only is required, two body numbers, or a one piece panel equivalent to this, shall be worn in all road and track events .

8.5.4 When photo finish equipment is being used for an event, shoulder or frame numbers must be worn or fitted as appropriate and shall be attached as specified.

*Note: Details of recommended sizes for numbers are available from B.C.F. Headquarters.*

## 8.6 Protective Headgear.

8.6.1 A rider whilst racing or training in any cycling discipline, with the exception of training on the open road shall wear properly affixed protective headgear which must be of a hard/soft shell construction. "Aero Style" helmets are acceptable for individual time trials (road or track) providing they are in line with that which is permitted under the current UCI regulations.

**Note:**

*In order to assist riders, the Federation advises all competitors that protective headgear must take the form of a hard/soft shell helmet which should conform to a recognised Standard such as SNELL B95 (Snell Memorial Foundation), AUS/NZS 2063:96 (Australian and New Zealand standard), DIN 33-954 (TUEV Institute Germany), CPSC or EN 1078 (Europe). Other Standards are available, but competitors and/or parents/guardians should obtain proof that a Standard is adequate for the purpose for which they intend to use the article.*

*The current British Standard (BS 6863) is primarily intended for use by young riders. This standard is not intended to provide a complete specification for helmets for high speed or long distance riding. A copy of the complete foreword to the British Standard can be obtained from B.C.F. Headquarters.*

*It is emphasised that it is the responsibility of the rider (or the parent or guardian if the rider is under 18 years of age) to select a standard of protective headgear which offers protection against head injury and does not restrict the rider's vision or hearing. This responsibility also applies to ensuring that the headgear is undamaged and in good condition. It is pointed out that any helmet which suffers damage (e.g. in the case of an accident or through mishandling) may no longer afford the same level of protection.*

*The Federation makes no warranties or representations regarding the adequacy of any Standard or the fitness for the purpose of any brand of protective headgear and will not accept any claims arising from the use of any particular headgear.*

## 9 ADVERTISING AGREEMENTS

9.1 Any Affiliated Club, Centre of Excellence, Region, Trade Team or individual member may enter into agreement with commercial sponsors of unlimited number.

9.2 Each sponsorship agreement entered into by a club, trade team or individual rider will be required to be registered with the Federation at the start of each season, together with details of jersey design and placing of advertising material.

9.3 Two copies of the advertising agreement registration form should be forwarded to the Competition Director of the Federation together with the appropriate fee.

9.4 Each advertising agreement must be registered with the Federation annually, even if the agreement between the parties covers a longer period.

9.5 Riders, once subject to a formal agreement, may display without restriction any related advertising material, with the exception of political signs, on clothing, etc.

9.6 Riders shall not compete in the name of, wear the colours or advertising material of, nor have their names or cycling performances advertised in any manner whatsoever by any sponsor unless the latter is currently registered with the Federation.

## 9.7 Contracts

9.7.1 Individual riders entering into personal contracts, either directly with a sponsor or with a third party, as part of a team or individual agreement, may, if they wish, lodge with the Federation details of the core elements of their personal contract without disclosing specific financial details confidential to parties to the contract.

9.7.2 No rider shall enter into contract with more than one main sponsor, or group of main sponsors, nor with more than one secondary sponsor for a specific accessory.

9.7.3 No rider shall contract with a secondary sponsor without the approval of the main sponsor with whom he has an existing contract.

9.7.4 Any dispute between the parties to a contract made under this Regulation shall be decided by the Board. Its decision shall be final and binding on all parties.

9.7.5 Should a rider involved in such dispute be considered at fault, he shall be regarded as being in breach of these Regulations and may, in addition, be required to return or make good to his sponsor or sponsors any benefit he has received under the contract. This shall also apply to a rider penalised for any other breach of these Regulations.

9.7.6 Where a sponsor shall be considered at fault his sponsorship may be suspended in which case the Board shall rule that:

9.7.6.1 Any riders under contract to him shall then be free to compete as individuals but not to enter into any other contracts, or

9.7.6.2 The sponsorship may be revoked entirely, in which case the riders shall be free to enter into other contracts by permission of the Board. No benefits had by the riders shall be returnable in this case, but the sponsor may be held liable for the full payment of contract fees, or

9.7.6.3 The contract declared void, in which case the parties shall be free to enter into new contracts.

9.7.7 Every contract shall be valid for a period of two years from the date specified therein, and shall be registered with the Chief Executive of the Federation. Where the period of the contract runs from one year into another the contract shall become void from the 1st January of the second year unless and until such time as the rider concerned shall have renewed his licence from the Federation for that year.

**Note:**

*An information leaflet giving contract advice to clubs and individual riders is available from the Competition Directorate on request.*

## 9.8 Advertising Material

9.8.1 All riders under contract shall wear the colours and advertising material of the sponsor, and their names and cycling performances may be advertised. In such advertisement the correct title, style and year must be stated.

9.8.2 The inscriptions on each item of clothing shall comply with the requirements laid down from time to time by the Board in accordance with U.C.I. Regulations.

9.8.3 No sponsor may advertise past successes unless currently registered with the Federation and having riders under contract. No rider's name or performances shall be used by the sponsor for publicity purposes unless that rider is currently under contract.

9.8.4 Trade team vehicles, and other vehicles used for the purpose of race service support to sponsored clubs, must carry the names of the principal sponsors.

- 9.9 **Event Entries and Contracts**
- 9.9.1 The sponsor or his agent may enter his riders under contract in events, and all negotiations concerning these riders shall be between the organiser and the sponsor or his agent.
- 9.9.2 A rider under contract retiring from a race after the start for no apparent good reason shall be the subject of special enquiry by the Chief Commissaire who shall report the matter to the Board if necessary.
- 9.9.3 Throughout an event no publicity matter associated with the contracted riders competing shall be concealed, defaced or otherwise obscured until the event is declared completed by the Chief Commissaire.
- 9.9.4 Appearance and/or starting money may only be paid as permitted by U.C.I. Regulations, and in such circumstances a contract will be entered into. This contract may be revoked by mutual agreement in writing, up to 15 days before the commencement of the event but, if not so revoked, the contract shall be binding.
- 9.9.5 When a rider is not contracted as in T.R. 9.9.4 above, he shall submit an entry form to the organiser.
- 9.9.6 Entry for events shall be governed by T.R. 20.4.1.
- 9.10 Regions may register Advertising Agreements in accordance with the provisions of the Bye Laws, except that no fees shall be payable.
- 9.11 These Regulations, and all decisions of the Board in relation to sponsorship issues, shall be binding on all sponsors, whether main or secondary.
- 10 MISCELLANEOUS**
- 10.1 All those who compete in any of the events authorised under these Regulations do so at their own risk, whether or not they be members of the Federation, and no liability shall attach to the Federation or to any of its officials in respect of any loss or injury sustained or caused by anyone competing in such events.
- 10.2 All entry forms, prospectuses, programmes, start and finishing sheets, contracts, advertisements (except for those which appear in official Federation publications) and other similar literature used or displayed in connection with races held under these Regulations must bear the words 'Under the Technical Regulations of the British Cycling Federation and, except for contracts and advertisements, must bear the name and address of the organiser.
- 10.3 Any competitor who is not ready at the advertised time of start of a heat or race, or when called upon to start, shall not be allowed to compete.
- 10.4 Any member who strikes or interferes with another member during the course of an event or whilst still under the jurisdiction of the commissaire(s) or as a consequence of any race shall be liable to disciplinary action.
- 10.5.1 If a rider falls in the course of a race and is assisted on to his machine by another person, he is entitled to any prize he may win, and is not disqualified by reason of this outside assistance.
- 10.5.2 If a cycle be disabled in a race, the rider may use another cycle which fulfils the conditions of T.R. 3.
- 10.6 It shall be a breach of these Regulations for riders to combine or conspire improperly to affect the course of a race, but this Regulation shall not prevent the employment of ordinary team tactics by members of the same team.
- 10.7 The placings of competitors at the finish of a race shall be according to the order in which the first part of their respective machines crosses the finishing line.
- 10.8 A race shall end, if no time has been fixed or other notification made beforehand when the last rider has crossed the finishing line, or at the discretion of the Chief Commissaire.
- 10.9 Any dispute or complaint which may arise in connection with any racing under these Regulations, except in regard to those matters in which the decision of the Chief Commissaire is final, shall be referred to the Region issuing the permit for the racing.
- 10.10 The promoter of any event shall have the right before the day of the event to make any alterations that he may deem necessary to the published programme except that the prize values may not be reduced and where a programme is timed, no heat or race may be started before the time stated in the programme, except with the consent of all the competitors in the heat or race.
- 10.11 No Club, Association, Promoter, Sponsor or an Agent for any such Club, Association, Promoter, or Sponsor may enter into negotiations for or permit any cycling event to be televised either live or subsequently, or filmed, video taped, or sound recorded, without the prior permission in writing of the B.C.F. This Regulation shall not apply to films, tapes or recordings made and used solely for news coverage.
- 10.12 Betting is only permitted on racing held under these Regulations if conducted under conditions laid down by the Board.
- 10.13 No lotteries may be held on any events held under B.C.F. Technical Regulations or U.C.I. Regulations except with the permission of the Board.
- 11 BANNED SUBSTANCES**
- 11.1 The administration to, or use by, a rider of a banned substance or method shall be a breach of the Technical Regulations for all disciplines of British Cycling Federation and Cycling Time Trials events.
- 11.2 Any rider or other person committing or attempting to commit a fraud which may influence the result of a test shall also be in breach of these Regulations.
- 11.3 Any Member of the Federation or other person who is directly or indirectly an accessory to the fact in the case of a rider being found to have breached T.R.11.1 or 11.2 shall be deemed to be in breach of the Regulations.
- 11.4 The procedures laid down in the Federation's Anti-Doping Regulations, which shall be considered to be an integral part of these Technical Regulations, shall apply to all tests for banned substances and methods carried out at races held under these Technical Regulations and to tests for banned substances and methods conducted on members outside of competition, including the whereabouts requirements and responsibilities which apply to selected riders in the UCI and the National Whereabouts Pools.
- 11.5 The Federation's Anti-Doping Regulations shall be subject to amendment from time to time by the Board to ensure that the Regulations continue to comply with the Anti-Doping Examination Regulations of the U.C.I. and/or WADA and advice supplied by the relevant Advisory Bodies.
- 11.6 All disciplinary matters in connection with alleged breaches of the Federation's Anti-Doping Regulations shall be dealt with by an Anti-Doping Tribunal appointed by the BCF Board The procedures for hearings shall be as laid down in the Federation's Bye-Laws.
- Note: Full details of the Anti-Doping Regulations and the List of Prohibited Substances are available from BC Headquarters or from the UCI Website.*

## 12 RACE INFRINGEMENTS AND PENALTIES

- 12.1 Depending on the nature of the offence, commissaires may at their discretion impose a range of penalties upon riders, managers, helpers or officials.  
Such penalties may range from a reprimand/warning, relegation, time or points penalty, disqualification or a fine.
- 12.2 Fines may be imposed on any category of rider in any type of event. In deciding upon the most appropriate form of penalty to impose, commissaires must take into full account the nature of the offence and the category of rider concerned.
- 12.3 Where fines are imposed the guide for race infringements by Elite category riders shall be:
- 12.3.1 Ignoring road and traffic signs.
- 12.3.1.1 Single day race.
- 12.3.1.1.1 First offence. Minimum fine £5.00; maximum fine £15.00 or all of the prize money won in the race if over £15.00;
- 12.3.1.1.2 Second offence. Minimum fine £10.00; maximum fine £30.00 or all of the prize money won on the race if over £30.00;
- 12.3.1.1.3 Third offence. Minimum fine £25.00; maximum fine £75.00 or all of the prize money won on the race if over £75.00;
- 12.3.1.1.4 Fourth offence. Disqualification.
- 12.3.1.2 Stage race.
- 12.3.1.2.1 First offence. Minimum fine £5.00; maximum fine £15.00 or all of the prize money won on the stage during which the offence was committed if over £15.00 plus a time penalty of 2 minutes.
- 12.3.1.2.2 Second offence. Minimum fine £10.00; maximum fine £30.00 or all of the prize money won on the stage during which the second offence was committed if over £30.00 plus a time penalty of 5 minutes.
- 12.3.1.2.3 Third offence. Minimum fine £25.00; maximum fine £75.00 or all of the prize money won on the stage during which the third offence was committed if over £75.00 plus a time penalty of 5 minutes.
- 12.3.1.2.4 Fourth offence. Disqualification and all prize money won during the stage forfeited.
- 12.3.2 Pacing
- 12.3.2.1 Single day race. Minimum fine £10.00; maximum fine £20.00. The Chief Commissaire may also disqualify.
- 12.3.2.2 Stage race. Minimum fine £10.00; maximum fine £20.00 plus a time penalty of 20 seconds per offence.
- 12.3.3 Towing. Fine £100.00 plus disqualification.
- 12.3.4 Race conduct. Minimum fine £5.00; maximum fine £100.00. The Chief Commissaire may also disqualify.
- 12.3.5 Race procedure. Maximum fine £10.00.
- 12.3.6 Dangerous riding
- 12.3.6.1 Single day race
- 12.3.6.1.1 First offence. Minimum fine £10.00; maximum fine £30.00 or all prize money won on the race if over £30.00.
- 12.3.6.1.2 Second offence. Minimum fine £40.00; maximum fine £75.00 or all prize money won on the race if over £75.00.
- 12.3.6.1.3 Third offence. Disqualification.
- 12.3.6.2 Stage race
- 12.3.6.2.1 First offence. Minimum fine £10.00; maximum fine £30.00 or all of the prize money won on the stage when the offence was committed if over £30.00 plus a time penalty of 2 minutes.

12.3.6.2.2 Second offence. Minimum fine £50.00; maximum fine £150.00 or all of the prize money won on the race if over £150.00 plus a time penalty of 10 minutes.

12.3.6.2.3 Third offence. Disqualification.

- 12.4 All fines under this Regulation shall be collected by the Chief Commissaire and forwarded direct to the Chief Executive of the Federation.

## 13 PRIZES

- 13.1 Unless the race has been subject to an Anti-Doping control, prizes must be presented on the day to their winners.
- 13.1.1 Where a single day race has been the subject of an Anti-Doping control, prizes due to riders selected for testing shall be withheld until the result of the control is known.
- 13.1.2 Where a stage race has been the subject of an Anti-Doping control, all prizes must be presented on the final day to their winners.
- 13.2 The award of any prize to a successful competitor shall be subject to his eligibility to compete, and to the statements on his entry form being accurate and complete.
- 13.2.1 If it be shown subsequently that a prize winner was not eligible, or that the statements on his entry form were inaccurate or incomplete, the award of the prize shall give him no claim or title to it and he must return it forthwith to the organiser of the event.
- 13.3 No rider shall be entitled to any prime or lap prize unless he completes the full distance of the race, or satisfies the Chief Commissaire that his retirement is due to some good and sufficient reason.
- 13.4 In open road races mixed or composite teams consisting of riders from different clubs or sponsors will not be eligible for a team award, unless the teams be national, area, centre of excellence, or Region teams entered as such.

## 14 CALENDAR OF EVENTS

- 14.1.1 Each Region shall, by the 21st October in each year, compile a calendar of the forthcoming year's races in its area, holding a Date Fixing Conference of organisers if necessary.
- 14.1.2 The Region shall adjudicate when two or more events clash in date and/or route, and its decision shall be final.
- 14.2 A copy of each Region's Calendar for the forthcoming year shall be sent to the Competition Director of the Federation by 30th October, accompanied by that part of the permit fees for the events listed in the Calendar due to be sent to the Competition Director under the provisions of T.R. 15.2. The Competition Director of the Federation shall compile a National Calendar incorporating the Region Calendars as submitted to him. The National Calendar shall be reproduced in the Federation Racing Handbook. Non-standard closing dates and events where entries will be accepted on the day shall be so indicated as will the categories of riders from whom entries will be accepted, e.g. E, 1, 2, 3, 4, Jun, Youth A, B, C, D or E, W1, W2, W3, W4, or the various Masters categories. The description "All" is not acceptable.
- 14.3.1 The levies and any temporary single event licence fees (as detailed in Bye-Laws 3.5, 3.7 and 3.8) shall be collected by the race organiser and forwarded, no later than 7 days after the event, to the **Regional Competition Administrator** of the Region issuing the permit. The organiser shall forward with the levies two copies of the programme, indicating those reserves, if any, whose levy was returned as per T.R. 20.2.7.3., and the levy return form completed by the Chief Commissaire. In the case of races where entries have

been taken on the day a copy of the signing on sheet must be sent in place of one of the programmes.

14.3.2 The Region Treasurer shall make a detailed return to the Federation Chief Executive for each calendar month, setting out all events held in the Region for which the levy is due during the month whether payment has been received for them or not and where possible giving the number of entries received in those events and the amount paid by the organiser to the Region Treasurer. This shall be done within 14 days of the end of the month and shall be accompanied by the levies and any day membership and licence fees received by the Treasurer during the period in question.

14.3.3 Where an organiser fails to forward the levy within 7 days of the event the Region Treasurer should report the matter to the appropriate Region Race Secretary, as the case may be, who shall issue no further permits to the organiser or promoting club or organisation until the outstanding levy is paid and withdraw any permits already issued. The Treasurer shall also report the matter to the Region Committee for disciplinary action to be taken.

## 15 PERMITS

### 15.1 Standard Event Procedures

15.1.1 A Club, Association, or organisation, whether or not affiliated to the Federation, wishing to promote an event on the open road or on a circuit under these Regulations (other than those referred to in T.R. 15.2.1.) shall apply to its local Region for a permit at least eight weeks prior to the date of the proposed event.

15.1.2 A Club, association, or organisation, whether or not affiliated to the Federation, wishing to promote a Track or Closed Circuit Meeting under these Regulations (other than those referred to in T.R.15.2.1.) shall apply to the Region having jurisdiction over that track or closed circuit, for a permit at least eight weeks prior to the date of the proposed event.

15.1.3 No event may be styled as a championship (except a club or association championship) without the approval of the Region concerned.

15.1.4 No event may be styled as a National Championship without the approval of the Board.

15.1.5 Organisers of race meetings on closed circuits or closed roads or on tracks shall include events for youth category riders and/or non-members. The Board or Region, as the case may be, shall have the power to waive this Regulation upon the request of the event organiser.

15.1.6 No event shall be sanctioned by the permit issuing body without the completion and submission of the appropriate Risk Assessment to that body.

### 15.2 Special Event Procedures

15.2.1 Applications for permits for races by organisations not affiliated to the Federation, or applications in respect of international events on the U.C.I. Calendar, National Championships, the Tour of Britain, events lasting 5 days or more and events counting for a Federation trophy shall be forwarded to the appropriate Competition Administrator for Region approval at least 12 weeks prior to the date of the proposed event.

15.2.2 Following Region approval, the appropriate Competition Administrator shall forward the application to the Headquarters of the Federation for the attention of the Board.

15.2.3 The permit shall be issued by the Board.

15.2.4 The granting of a permit to events within the jurisdiction of the Board shall involve the signing of such contracts as the Board sees fit, to ensure that

such race or races take place, that prize monies are all paid, and that other necessary facilities be provided, dependent on the stature of the promotion concerned.

15.3 If a permit be granted it may subsequently be withdrawn by the Region concerned or by the Board.

### 15.4 Circuit Races

15.4.1 An application for a permit for circuit racing shall describe the course to be used, and if it has not previously been used for such racing the Region shall be given facilities for an inspection of the course if so desired.

15.4.2 No circuit race shall be held on a circuit of less than one kilometre in circumference without the permission of the Region.

15.4.3 Where a circuit is within the jurisdiction of another Region application must have been made to and approval given by the Secretary of that Region prior to the permit being issued.

### 15.5 Road Races

15.5.1 An application for a permit for a road race shall describe the course to be used (giving DoT numbers of the roads), and if it has not previously been used for a road race, the Region shall, if necessary, cause an inspection of the course to be carried out.

15.5.2 Once approved, a course shall not be altered without the permission of the appropriate Chief Constable. The term Chief Constable shall, where necessary, mean the police officer appointed to deal with road racing under the Regulations.

15.5.3 Where a course extends into the area of another Region, application for approval must have been made to and had from the Secretary of that Region prior to application being made to the police.

15.5.4 The application shall be accompanied by as many copies of the preliminary race details as are necessary to supply six copies for each Chief Constable in whose area the road race or part of it takes place, and two copies for the use of the Region. The preliminary race details shall include the course description; the length of the race; time of start; number of starters; and, where exemption is required from any of the provisions in paragraph 5(1) of the Cycle Racing on the Highway Regulations, such details as are necessary to support the application for exemption.

15.5.5 Where the preliminary race details are approved by the Region, six copies of such details shall be forwarded by the Region to each Chief Constable in whose area the road race or any part of it takes place not less than seven weeks prior to the event.

15.6 All dealings with Chief Constables shall be by Regions.

*Note: Please refer to the Cycle Racing on the Highways Regulations in the reference section of this Rulebook.*

## 16 COMMISSAIRES AND OFFICIALS

16.1 The control of races shall be conducted by Commissaires trained and registered by Regions or the Board as meeting the standards required for each discipline.

16.2 Registered Commissaires shall be graded as follows:

16.2.1 International Commissaires

16.2.2 National Commissaires

16.2.3 Senior Commissaires

16.2.4 Regional Commissaires

16.2.5 Assistant Commissaires

16.3.1 The Board shall set standards for training and qualifications for the training and registration of Commissaires at National, Regional and Assistant level which shall be published from time to time.

- 16.3.2 The Federation shall, at intervals not exceeding 5 years, conduct examinations to enable Regional Commissaires to qualify as National Commissaires.
- 16.3.3 The Board shall biennially seek evidence from individuals registered as National Commissaires of their continuing activity as Commissaires. Failure to provide such evidence may result in individuals being removed from the list of qualified persons.
- 16.3.4 International Commissaires shall be those commissaires who have passed a UCI examination as UCI International Commissaire.
- 16.3.5 Successful candidates shall be provided with an armband indicating their qualification. This armband shall be worn when the individual is acting as a Chief Commissaire.
- 16.4 International and National Commissaires may act in any part of the territory controlled by the Federation.
- 16.5.1 The appointment of Chief and Assistant Commissaires and Handicappers for track, road and circuit racing shall be subject to the approval of the Region or BCF HQ as appropriate.
- 16.5.2 No appointment shall be made allowing a person to act as the Chief Commissaire for a race promoted by a club of which he is a member. Subject to Region approval an exception may be permitted for closed circuit races for provisional licence holders where an Assistant Commissaire can be appointed from the promoting club and may fulfill the role of a Chief Commissaire for this type of event only.
- 16.5.3 The appointment of other officials shall rest with the organiser except that he must choose from the lists published by the Board or Region as the case may be.
- 16.6.1 The key Commissaires for events listed in T.R. 15.2. shall be appointed by the Board.
- Officials so appointed must have successfully completed an approved and appropriate Commissaires Course as a U.C.I. or National Commissaire.
- An official appointed to an event by the Board or a Region Committee shall be paid all out-of-pocket expenses
- 16.7.1 All persons appointed as event officials shall be permitted to wear uniform and advertising material issued by the event organiser.
- 16.7.2 Such material shall in general comply with regulations applicable to sponsored clubs (lettering sizes etc.).
- 16.7.3 The Chief Commissaire in conjunction with the event organiser can insist on appointed officials removing advertising material they consider inappropriate to the meeting concerned.
- 16.8 The officials at any racing authorised under these Regulations may not compete in the racing.
- 16.9.1 The Chief Commissaire shall have power to decide:
- 16.9.1.1 whether a competitor is properly entered (including if he possesses a current licence, or is under penalty); or
- 16.9.1.2 if a competitor is eligible for a race.
- 16.10.1 The Chief Commissaire shall, within four days of the event, report in writing to the appropriate Region any disqualification imposed or fine levied by him at such meeting. Such disqualification or fining shall not preclude further disciplinary action by the Region.
- 16.10.2 Any disqualification or fine reported by a Chief Commissaire to a Region shall be reported by the latter to the Chief Executive of the Federation.
- 16.10.3 It shall be the duty of the Chief Commissaire to notify Headquarters within 3 days of the details of riders having gained placings for points scoring.
- 16.10.4 Points achieved will be added to the National Ranking of all riders and updated lists of category changes will be issued by Headquarters on a monthly basis.
- The Chief Commissaire of a race must include in his report details of any accidents requiring medical treatment, involving a third party, or damage to property which occur during the course of the race and prepare and submit a separate incident report form in relation to such accidents. He shall ensure that a copy of the incident and commissaire's report is forwarded direct to Headquarters.
- Note: A reportable accident is one that involves a third party or where any rider or official receives medical attention.*
- 16.11 Protests against decisions made by the Commissaires/Referees should be laid with the Chief Commissaire/Referee whose decision shall be final.
- 16.12 Except in regard to reporting disqualifications or fines, the powers of a Chief Commissaire/Referee shall end when the other officials for the event have dispersed.
- 16.13 The following minimum fees and expenses shall be paid by the promoting organisation:
- 16.13.1 International races – commissaire panel members not appointed by the UCI - £50 fee plus 25p per mile. All other BC appointed officials, £25 plus 25p per mile.
- 16.13.2 National A races and other senior and non-road discipline events of similar stature – BC appointed chief commissaire £30 fee plus 25p per mile. All other BC appointed officials, £20 plus 25p per mile. Fees are per day
- 16.14 Timekeepers**
- 16.14.1 The appointment and re-appointment of Chief and Assistant Timekeepers shall rest with the Board, to whom application must be made by the individual concerned supported by a recommendation from his Region. Such Timekeepers must use both time of day chronographs and stop watches which possess certificates as detailed in T.R. 16.14. Certificates concerning the watches used by Chief and Assistant Timekeepers must accompany application for appointment or re-appointment.
- 16.14.2 No individual shall be appointed a Chief Timekeeper unless he has previously held appointment as an Assistant Timekeeper for at least one year, save that the Board may waive this qualification where it is satisfied the individual warrants immediate appointment as a Chief Timekeeper.
- 16.14.3 The appointment and re-appointment of operators of fully automatic electronic timing devices shall rest with the Board.
- 16.14.4 Regions may appoint Regional Timekeepers, who must be members of the Federation, for the purpose of timing Regional Championships and other Regional races.
- 16.14.5 The Timekeeper, where employed, shall take the times of the first in each race, and such other times as the Chief Commissaire may call for, or as the organiser may previously have arranged with the timekeeper. Where more than one timekeeper is employed, the slower time for two, and the middle time for three, timekeepers shall be taken, unless two of three agree, in which case the agreed time shall be taken. Where a fully automatic electronic timing device is employed the time recorded by that device shall be taken. Hand held devices shall be for back-up only.
- 16.14.6 Regional Timekeepers may use a timing device in accordance with T.R. 16.14 or they may use watches or electronic timers which have been submitted to and obtained a certificate from a watch tester approved by the Board. Each watch must possess at least one independent centre second hand, and must during the previous twelve months have obtained a certificate showing a rate of error not exceeding 15 seconds a day in pendant up, dial up and dial down positions.

The performance of the chronograph shall be satisfactory in all cases. Regional Timekeepers may use a stopwatch or chronograph watch not showing time-of-day for events not exceeding 5 km.

## 16.15 Watches and Timing Devices

- 16.15.1 Timing devices used by Chief and Assistant Timekeepers shall be hand-held spring driven time-of-day chronographs or stopwatches, or they may be hand-held quartz-crystal-controlled timers. They shall meet the appropriate conditions prescribed below.
- 16.15.2 Time-of-day chronographs and stop watches shall have obtained during the last 36 months a National Physical Laboratory or British Calibration Service Craftmanship or Sporting Test Certificate or a first class Neuchatel Certificate.
- 16.15.3 Spring driven time-of-day chronographs and stop watches shall have a movement of a size not less than 19 ligne and shall have at least two centre second hands capable of being split, except that stopwatches with escapements faster than 1/10th second may have only one centre second hand.
- 16.15.4 Quartz crystal controlled timers shall have a digital display with a height of not less than 5 mm showing times to at least 1/10th second, they shall have a split facility and be capable of recording two or more times. They shall have a battery life of at least 100 hours when in full display (this would mean a liquid crystal display, L.C.D.). They shall have obtained a certificate from a nationally recognised standardising organisation showing errors within acceptable limits, as shown below this Regulation. Quartz crystal controlled timers need re-certification only if any timing component has been disturbed, modified or adjusted.
- 16.15.5 Certificate of Measurement :
- 16.15.5.1 60 mins 20±1 deg. C. 0 0.002%
- 16.15.5.2 60 mins 4±1 deg. C. 0 0.003%
- 16.15.5.3 60 mins 36±1 deg. C. 0 0.003%
- 16.15.5.4 6 hours 20±1 deg. C. 0 0.002%
- 16.15.6 Quartz crystal controlled timers may be used to time any distance but when spring driven devices are used, then for events up to and including 1 km a stopwatch with a 1/10th or faster escapement shall be used. For events above 1 km up to and including 5 km a stopwatch or a time-of-day chronograph with a 1/10th second escapement shall be used. For events above 5 km, a time-of-day chronograph shall be used.
- 16.15.7 For track and roller events all timing shall be to 1/10th second. For road and circuit events timing shall be to the next whole second.
- 16.15.8 A fully automatic electronic timing device as approved by the Board may be used. Such devices shall be certified in accordance with T.R. 16.14.5. Where they are used the times shall be recorded to the nearest 1/1000th of a second. Records manually timed shall be as required by T.R. 26.4.
- 16.15.9 The Board may from time to time issue methods of test for the guidance of watch testers.

## 17 NATIONAL CHAMPIONSHIPS

- 17.1 The holding of each National Championship shall be at the discretion of the Board, and the Board may cancel the holding of any National Championship where it is of opinion that the quantity or quality of the entries received, or the arrangements made, for such Championship do not justify holding the Championship. The Board shall be empowered to delete a National Championship where the number of starters is less than ten over two consecutive years.
- 17.2 Each National Championship shall be under the control of the Board, it may make such arrangements as it thinks fit, provided the actual racing is under the control of Federation officials.

- 17.3 The Board shall issue a set of conditions to each competitor for each Championship as applicable. In the case of Track Championships they shall follow as closely as possible the World Championship Regulations of the U.C.I. Secretaries of member clubs and team managers with riders participating in the Track Championships may obtain one copy of the regulations from the Championship organisers.
- 17.4 The Board may send two members of the Board in advance to the scene of any Championship, to see that the arrangements for the Championship are satisfactory.
- 17.5 The Board shall be open to consider tenders for National Championships direct from Regions, affiliated clubs, individual members, or organisers, except that no two track championships for the same sex may be promoted on different tracks on the same day. The Closing date for Tender Applications for the promotion of the Elite Men's National Road Race Championship shall be 1<sup>st</sup> January of the previous year. 31<sup>st</sup> July shall be the closing date for all others.
- 17.6.1 National Championships shall be open to Silver and Gold category members of the British Cycling Federation who are citizens of the United Kingdom and dependent Territories, the Isle of Man, or the Channel Islands. With the exception of the Cycle Speedway Championships, competitors must hold a valid licence showing the UCI prefix "GBR" and issued at least 28 days prior to the event. If resident in another Country they must hold a United Kingdom passport and must not, in the same year, have competed in the National Championship of any other U.C.I. affiliated National Federation. In the Motor Paced and Derny Championships, pacers may be foreign nationals who must hold the appropriate licence of their own National Federation or the British Cycling Federation.
- 17.6.2 The closing date for entries for national championships shall be 28 days prior to the advertised date. Entries on the day shall not be permitted for any national championship event. Only those riders listed on the pre championship published list of entries may start, except in cases specifically approved by the Board.
- 17.7.1 The field shall be composed of the best riders entered, the selection being based on current form.
- 17.7.2 The heats (if any) for each Track Championship shall be arranged by the Chief Commissaire from among the entries reporting to him at the venue for the Championship. The Chief Commissaire shall also arrange the heats for each successive round of the Championship.
- 17.7.3 National Grass Track Championship events of 800m or less should be run over heats, repechages, semi finals and finals, with the exact composition determined by the principle that the heats should consist of no less than four riders and no more than seven riders and the finals should be contested by 4-6 riders. Where there are less than fifteen riders taking the start, the semi final can be dispensed with.
- 17.8.1 A Championship jersey shall be awarded to the winner, and medals finished in gold, silver and bronze of Championship design shall be presented as follows:

Men/Women/Junior Championships –	8 or more entries	3 Medals & Jersey
Men/Women/Junior Championships –	6/7 entries	2 Medals & Jersey
Men/Women/Junior Championships –	3-5 entries	1 Medal & Jersey
Masters/Youth/Disability Championships –	5 or more entries	3 Medals & Jersey
Masters/Youth/Disability Championships –	4 entries	2 Medals & Jersey
Masters/Youth/Disability Championships –	3 entries	1 Medal & Jersey

- 17.8.2 In respect of the Team Pursuit and Team Sprint Championship, the awarding of additional medals will be as per the current U.C.I. Regulations.
- 17.9 Where possible, three Chief Timekeepers should be engaged at each Track Championship meeting.
- 17.10.1 The National Championships shall be conducted under the Conditions set out in these Regulations over the distances shown below, except that the exact distances for all sprint events shall be adjusted by the Board to a distance in whole laps to suit the specific venue.
- 17.10.2 Youth Road Championships
- 17.10.2.1 Region and Area Champions shall be guaranteed acceptance of entry to the National Championships as shall the Champions of the Scottish Cyclists' Union and the Welsh Cycling Union. All further entries shall be selected on merit.
- 17.10.2.2 Each entrant must be the holder of a Youth Licence for the appropriate age group.
- 17.10.2.3 The National Championships shall be held on or following the third Saturday in July and before the last Sunday in August but so that it shall not clash with another National Youth Championship.
- 17.10.2.4 The entry fee for the National Championships, payable by all entrants, shall be determined by the Board.
- 17.11 MEN'S CHAMPIONSHIPS**
- 17.11.1 Hard Tracks: -**  
 Sprint  
 1 kilometre Standing Start Time Trial  
 4000 metres Individual Pursuit  
 4000 metres Team Pursuit for Club, Trade and Region teams (teams may include women)  
 20 kilometres Scratch Race  
 Points Race  
 Madison for two-up teams  
 Omnium  
 Keirin  
 Team Sprint for Club, Trade and Region teams (teams may include women)  
 Tandem Sprint.  
 Derny – to be run under terms and conditions as laid down by the Board.
- 17.11.2 Grass tracks :-**  
 400 metres Sprint  
 800 metres Scratch Race  
 8 kilometres Scratch Race
- 17.11.3 Road :-**  
 Senior Road Race  
 Closed Circuit Criterium  
 Senior Individual Time Trial  
 Under 23 Individual Time Trial  
 Under 23 Road Race
- 17.11.4 Mountain Bike :-**  
 Senior (Elite) Cross Country  
 Senior (Elite) Downhill  
 Senior (Elite) Four Cross  
 Senior (Elite) Endurance  
 Under 23 Cross Country
- 17.12 WOMEN'S CHAMPIONSHIPS (SENIOR)**
- 17.12.1 Hard Tracks :**  
 Sprint  
 500m Standing Start Time Trial  
 3000 metres Individual Pursuit  
 Points Race  
 Keirin  
 Derny – to be run under terms and conditions as laid down by the Board.  
 15 kilometres Scratch Race  
 Team Sprint for clubs, trade and regional teams.
- 17.12.2 Grass Tracks - 800 metres Scratch Race**
- 17.12.3 Road :-**  
 Road Race  
 Closed Circuit Criterium  
 Individual Time Trial  
 Under 23 Road Race  
 Under 23 Time Trial
- 17.12.4 Mountain Bike :-**  
 Senior (Elite) Cross Country  
 Senior (Elite) Downhill  
 Senior (Elite) Four Cross  
 Senior (Elite) Endurance  
 Under 23 Cross Country
- 17.13 CHAMPIONSHIPS FOR THE DISABLED**
- 17.13.1 Disability Categories will be as defined by the current edition of the International Paralympic Committee (IPC) Handbook.
- 17.13.1.1 Proof of IPC Medical Classification may be required.
- 17.13.1.2 Disability Categories - Any Age, Both Gender, of those disabilities as deemed appropriate to participate in a BC National Cycling Championship by the Executive Board. The competitors performance measured as a percentage of the estimated or actual World Best Time as appropriate.
- 17.13.2. Hard Tracks:**  
 200 Metre Flying Start Time Trial  
 1 kilometre Standing Start Time Trial  
 3,000 metre Standing Start Time Trial
- 17.13.3 Road**  
 1 hour closed circuit race  
 Individual Time Trial of 20-30 km.
- 17.13.4 Handcyclists**  
 Single Championships based on Index Times as approved by the Board based on World Best Times to allow for Handcycle Disability Categories A, B & C to compete against each other in each of the following-  
 i) Closed Road Circuit Race over 1 Hour  
 ii) An individual Time Trial of 20-30 km.
- 17.14 JUNIOR CHAMPIONSHIPS (MEN)**
- 17.14.1 Hard Tracks :**  
 Sprint  
 1 kilometre Standing Start Time Trial  
 Keirin  
 3000 metres Individual Pursuit  
 Points Race  
 20 kilometres Scratch Race
- 17.14.2 Road**  
 A Road Race at a distance of between 90 and 120 km.  
 An individual time trial over a distance of 20-30 km
- 17.14.3 Mountain Bike**  
 Cross Country  
 Downhill  
 Four Cross
- 17.15 JUNIOR CHAMPIONSHIPS (WOMEN)**
- 17.15.1 Hard Tracks:**  
 Sprint  
 500m Standing Start Time Trial  
 Keirin  
 2000 metres Individual Pursuit  
 Points Race  
 Scratch Race
- 17.15.2 Road**  
 A Road Race at a distance of between 60 and 80 km  
 An individual time trial over a distance of 20-30 km
- 17.15.3 Mountain Bike**  
 Cross Country  
 Downhill  
 Four Cross

- 17.16 YOUTH A CHAMPIONSHIPS (BOYS)**
- 17.16.1 Hard Tracks :**  
Sprint  
500 metres Standing Start Time Trial  
2000 metres Individual Pursuit  
Points Race  
Scratch Race
- 17.16.2 Road**  
A Maximum 45 km Circuit Race.
- 17.16.3 Mountain Bike**  
Cross Country, Downhill and Four Cross
- 17.17 YOUTH B CHAMPIONSHIPS (BOYS)**
- 17.17.1 Hard Tracks :-**  
Omnium consisting of:  
Sprint  
500 metres Standing Start Time Trial  
1500 metres Individual Pursuit.
- 17.17.2 Road –**  
A Maximum 25 km Circuit Race
- 17.18 YOUTH C CHAMPIONSHIPS (BOYS)**
- 17.18.1 Hard Tracks :**  
Omnium consisting of:  
Sprint  
500 metres Standing Start Time Trial  
1500 metres Individual Pursuit.
- 17.18.2 Road –**  
A Maximum 20 km Circuit Race.
- 17.19 YOUTH A CHAMPIONSHIPS (GIRLS)**
- 17.19.1 Hard Track :**  
Sprint  
500 metres Standing Start Time Trial  
2000 metres Individual Pursuit  
Points Race  
Scratch Race
- 17.19.2 Road -**  
A Maximum 35 km Circuit Race.
- 17.19.3 Mountain Bike -** Cross Country and Downhill
- 17.20 YOUTH B CHAMPIONSHIPS (GIRLS)**
- 17.20.1 Hard Tracks :-**  
Omnium consisting of:  
Sprint  
500 metres Standing Start Time Trial  
1500 metres Individual Pursuit.
- 17.20.2 Road -**  
A Maximum 25 km Circuit Race.
- 17.21 YOUTH C CHAMPIONSHIPS (GIRLS)**
- 17.21.1 Hard Tracks :**  
Omnium consisting of:  
Sprint  
500 metres Standing Start Time Trial  
1500 metres Individual Pursuit.
- 17.21.2 Road -**  
A Maximum 20 km Circuit Race.
- 17.22 MASTERS CHAMPIONSHIPS**
- 17.22.1 Hard Tracks**
- 17.22.1.1 Age Category A.  
Sprint, 1000 metre time trial, 3000 metre Individual Pursuit, Scratch Race and Points Race
- 17.22.1.2 Age Category B.  
Sprint, 1000 metre time trial, 3000 metre Individual Pursuit, Scratch Race and Points Race
- 17.22.1.3 Age category C.  
Sprint, 750 metre time trial, 3000 metres Individual Pursuit, Scratch Race and Points Race
- 17.22.1.4 Age category D.  
Sprint, 750 metre time trial, 3000 metres Individual Pursuit, Scratch Race and Points Race
- 17.22.1.5 Age category E.  
Sprint, 500 metre time trial, 2000 metres Individual Pursuit, Scratch Race and Points Race
- 17.22.1.6 Age category F  
Sprint, 500 metre time trial, 2000 metres Individual Pursuit, Scratch Race and Points Race
- 17.22.1.7 Age category G  
Sprint, 500 metre time trial, 2000 metres Individual Pursuit, Scratch Race and Points Race
- 17.22.1.8 Age category H  
Sprint, 500 metre time trial, 2000 metres Individual Pursuit, Scratch Race and Points Race
- 17.22.1.9 Age category I  
Sprint, 500 metre time trial, 2000 metres Individual Pursuit, Scratch Race and Points Race
- 17.22.2 Road**
- 17.22.2.1 Age Category A.  
Road Race at a minimum distance of 140 km.  
Individual Time Trial of 30 – 40 km.
- 17.22.2.2 Age Category B.  
Road Race at a minimum distance of 140 km.  
Individual Time Trial of 30 – 40 km.
- 17.22.2.3 Age Category C.  
Road Race at a minimum distance of 120 km.  
Individual Time Trial of 30 – 40 km.
- 17.22.2.4 Age Category D.  
Road Race at a minimum distance of 120 km.  
Individual Time Trial of 30 – 40 km.
- 17.22.2.5 Age Category E.  
Road Race at a minimum distance of 100 km.  
Individual Time Trial of 30 – 40 km.
- 17.22.2.6 Age Category F.  
Road Race at a minimum distance of 100 km.  
Individual Time Trial of 30 – 40 km.
- 17.22.2.7 Age Category G.  
Road Race at a minimum distance of 80 km  
Individual Time Trial of 30 – 40 km.
- 17.22.2.8 Age Category H.  
Road Race at a minimum distance of 80 km.  
Individual Time Trial of 30 – 40 km.
- 17.22.2.9 Age Category I  
Road Race at a minimum distance of 80 km.  
Individual Time Trial of 30 – 40 km.
- 17.22.3 Mountain Bike :-**
- 17.22.3.1 Age category A - I Cross Country, Four Cross and Downhill
- 17.22.3.2 Age category C - I Endurance
- Note: Separate Masters Championships will be held for male and female riders subject to the requirements of T.R.17.8.2 being met.*
- 18 REGIONAL CHAMPIONSHIPS**
- 18.1 A Region may hold Championships at such distances as it may decide (except that the minimum distances for Regional Road Championships shall be senior 130 km (80 miles), junior 80 km (50 miles), subject to the permission of the Board being previously obtained.
- 18.2 Two or more adjacent Regions may hold Joint Championships.
- 18.3 Individual Regional Championships shall be open to members who reside in that Region. A rider may only compete in the Individual Regional Championship of one region in any one year.
- 18.4 A person whose licence is registered in the name of a foreign club may, provided he fulfils all other requirements, compete in the Championships(s) of the Region in which he would normally reside when in Great Britain.

- 18.5 In events open only to teams, a club or trade team shall be entitled to select any rider who is a member of the said club or trade team, regardless of his place of residence.
- 18.6 The winner of any such Championship shall be described as the Champion of the Region in which the contest is held.
- 18.7 Medals finished in gold, silver, and bronze to a uniform Federation pattern and design shall be presented as follows:

Men/Women/Junior Championships –	8 or more entries	3 Medals
Men/Women/Junior Championships –	6/7 entries	2 Medals
Men/Women/Junior Championships –	3-5 entries	1 Medal
Masters/Youth/Disability Championships –	5 or more entries	3 Medals
Masters/Youth/Disability Championships –	4 entries	2 Medals
Masters/Youth/Disability Championships–	3 entries	1 Medal

- 18.8 Medals for Regional Under 16s Championships, shall be provided by the Federation without charge to the Region. The number of free sets offered to be at the discretion of the Chief Executive. Prizes may be given in addition.
- 18.9 The distances for Regional Championships should correspond to those set for the respective National Championships.
- 18.10 The entry fee for a Regional Championship shall be determined by the Region.
- 18.11 Senior regional track championships are open to Junior category riders. Youth A riders with the appropriate dispensation may compete in Junior championships and Youth B & C riders with the appropriate dispensation may compete in Youth A and B championships respectively.

## 19 DISCIPLINE

- 19.1.1 Where the Board or a Region, through one of its officials, receives a report of a disqualification or alleged breach of these Regulations within its jurisdiction the report shall within 14 days be placed before the Board or Council of the Region having power to deal with such matters, which shall decide by majority vote whether any charge be made against the person or organisation concerned.
- 19.1.2 If it is decided that a charge be made or further enquiry carried out, the Board or the Region may at its discretion suspend the person or organisation concerned from competing, officiating or organising under these Regulations, pending further enquiry or a hearing of the charge against him or it, but such suspension shall not be operative for a period of more than 14 days from the date of its imposition and notice of the suspension must be sent in writing by Recorded Delivery Postal Service to the person or organisation concerned.
- 19.1.3 Where such person or organisation requests an adjournment of the hearing any suspension shall remain in force during the adjournment.
- 19.2 If the Board or the Region decides to charge a person or organisation it shall summon such person or organisation (the accused) to appear before the appropriate Board or Committee as soon as possible or, where suspension has been exercised under T.R. 19.1.2, within 14 days of such exercise, to answer the charge under conditions as laid down by Bye-Law 16.
- 19.3 Where a person is suspended from competition under these Regulations or fined he may not compete in any event or act as an official of the Federation under these Regulations during the period of suspension or

until the fine is paid, and in the meantime his licence shall be surrendered to Headquarters. Headquarters shall produce and forward a new membership card with the competition section invalidated. Provided the terms of the suspension are within the same calendar year, the original licence may be re-issued at the end of the term of suspension or when any fine had been paid. Where applicable, a new licence can be obtained from Headquarters on payment of the standard replacement licence fee.

- 19.4 A suspension imposed or recognised by any organisation named in T.R. 19.5 shall be recognised by each of the organisations and there shall be no appeal from that suspension except through the organisation that inflicted it, except that the Federation reserves the right, upon request from a suspended rider or club, to review and to vary any suspension exceeding a period of six months in respect of events held under these Regulations.
- 19.5 The Federation recognises all sentences of disqualification and suspension passed within their jurisdiction by the Road Time Trials Council, Scottish Cyclists Union, Welsh Cycling Union, Amateur Swimming Association, National Skating Association, Amateur Gymnastic Association, Amateur Boxing Association, UK Athletics, Scottish Amateur Athletic Association, British Triathlon Association and by any of the Federations affiliated to the Union Cycliste Internationale.
- 19.6 Any suspension imposed upon a member of the Federation by the Federation shall apply world-wide during the period of that suspension.
- 19.7 All fines levied at events shall be recorded on the appropriate BC Penalty Form and forwarded to BC Headquarters. In cases when the event permit was not issued by HQ, it shall be the responsibility of BC Headquarters to forward fines to the body issuing the permit.

## 20 ROAD RACING

### 20.1 Officials

- 20.1.1 The officials at a road or circuit race shall consist of the Organiser, a Chief Commissaire and one Assistant Commissaire whose presence shall be obligatory, other Assistant Commissaires as necessary, a Finishing Commissaire and a Gear Checker {where necessary to ensure compliance with T.R. 3.3} , who must be either corporate, affiliated, private or life members of the Federation.
- 20.1.2 Other officials such as Timekeeper, Recorder, Lap Scorers, Licence Steward, and Marshals shall be appointed as necessary.

#### 20.1.3 Chief Commissaire

- 20.1.3.1 The Chief Commissaire shall be the senior official for road or circuit racing who shall decide on all matters concerning the race and who shall submit a written report to the Region or Federation office issuing the permit within 7 days of the event.
- 20.1.3.2 The powers and duties of a Chief Commissaire shall be as set out in these Regulations

#### 20.1.4 Other Commissaires

- 20.1.4.1 Assistant Commissaires at road or circuit racing shall have such powers and carry out such duties as the Chief Commissaire directs.
- 20.1.4.2 The Finishing Commissaire at road or circuit racing shall be responsible for the placing of riders in primes or at the finish of an event and in this respect his decision shall be final.

#### 20.1.5 Race Jury

- 20.1.5.1 The conduct of all stage races will be in the hands of a Race Jury.

20.1.5.2 The Race Jury will consist of the Chief Commissaire, Finishing Commissaire and the Race Organiser.

20.1.5.3 All decisions of the Race Jury shall be final.

## 20.2 Road Races

20.2.1 Road races may be scratch or handicap events, promoted singly, or in stages spread over a day or days consisting of scratch and/or handicap events. Handicap races may be individual, team or group events. In team handicaps all the members of a team shall be started together. In group handicaps each rider shall be individually handicapped and all riders with the same allowance shall be started together.

## 20.2.2 Junior Stage Races

20.2.3.1 Stage races for juniors must not exceed three days duration and may contain one days racing of 120 km if made up of 2 stages, the shortest of which shall be not less than 30 km.

20.2.3.2 Racing on other days shall not exceed 100 km each day.

20.2.3 Youth competitors may not take part in road races except on roads closed to all other traffic.

20.2.4 All "Youth A" races, with the exception of National Championships, shall also be open to junior and senior women in the 3rd/4th categories.

20.2.5 In road races the maximum number of starters shall be as approved by the Region up to a maximum of 80 except for the two events permitted a maximum of 100 under the Cycle Racing on the Highways Regulations, or as permitted by the appropriate officer of police.

## 20.2.7 Reserves

20.2.7.1 Reserves may be allowed up to 25% of the authorised number of starters.

20.2.7.2 These reserves to be notified on the programme or start sheet in order of preference, and allowed to ride in that order, provided that at no time shall the maximum number of riders exceed that authorised by these Regulations. Where there is a team award, a reserve replacing a rider in his own club or representative team shall have preference over all other reserves and shall be eligible for a team award. Entrants shall indicate on their entry form if they do not wish to be nominated as reserves.

20.2.7.3 When more than the permitted maximum number of riders present themselves for an event, entry fees and levies shall be returned to those reserves who, having signed on for the race, are not allowed to start.

## 20.3 Circuit Races and Closed Circuit Criteriums.

20.3.1 Circuit races and closed circuit criteriums may be scratch or handicap events, and the maximum number of starters shall be prescribed by the Region in whose area the circuit is located.

20.3.2 Circuit races and closed circuit criteriums for U16's shall not exceed 50 km.

20.3.3 In a circuit race held on any circuit of less than 2 km a rider who punctures, crashes, or suffers mechanical trouble will be permitted, except within the last five laps, to rejoin the race, after omitting one lap, in the same position as when the incident occurred, with the approval of the Chief Commissaire. Riders so affected will be considered not to be a lap in arrears and they may contest the race finish. Riders shall be permitted only one lap out per race unless otherwise allowed by the Chief Commissaire. Discretion is given to the Chief Commissaire to allow further laps out in the case of events where the majority of riders may otherwise be withdrawn. In extreme weather conditions affecting the race surface, the Chief Commissaire has the discretion to extend this facility to circuits from 2 to 3 km in length.

## 20.4 Entries

20.4.1 Entries for all road and circuit races must be made on the standard entry forms, as shown in the Appendices to these Regulations, and sent to the organiser by the closing date. The entry form must be signed and be accompanied by the appropriate entry fee, failing which the entry shall be void. The organiser may reject any entry, for whatever reason, and such rejections shall be returned to the entrants no later than three days after the closing date of the event. The organiser shall ensure that all entry forms are available at the race for inspection by the Chief Commissaire.

*Note: Those entering on the line need not submit an entry form but must complete the relevant sections of the signing on sheet*

## 20.4.2 Closing dates are as follows:

20.4.2.1 National Championships, Stage Races, Premier Calendar and International Races: 28 days before the date of the event.

20.4.2.2 Circuit Races: (i.e. events not subject to Cycle Racing on Highways Regulations) 6 days before the date of the event.

20.4.2.3 All other races: 20 days before the date of the event.

20.4.2.4 However the organiser may stipulate an alternative closing date or accept entries on the day of the race provided that the maximum permitted number of starters shall not be exceeded. Riders who submit entries on the day shall not be permitted to start in preference to riders whose names appear in the programme/start sheet. The fee for entries on the day may be up to a maximum of double the stated fee for that event. Any deviation from the standard closing dates shall be detailed in the handbook.

20.4.3 Organisers shall not accept entries from riders in categories other than those to which the listing in the B.C.F. Handbook indicates the event to be open.

## 20.5 Event Programmes

20.5.1 The organiser of a road race, excluding closed circuit criteriums, shall at least 10 days before the race send to the Region issuing the permit for the race as many copies of the start sheet and/or programme as are necessary to supply six copies for each Chief Constable in whose area the road race or part of it takes place, and two copies for the Region. The information in the start sheet and/or programme shall include the names of the accepted entrants, reserves (if any), description of the course, event headquarters, date, time and place of start, and names of officials together with the name and address of the organiser.

20.5.2 A copy of the start sheet and/or programme shall be sent to each race official, accepted entrant and reserve not later than seven days before the race except for closed circuit criteriums. Start sheets or programmes for entrants or reserves being members of the same club may, with their agreement, be sent to a named official of that club.

20.5.3 The organiser of a circuit race shall not less than 3 days before the event inform each entrant of the venue, event headquarters, and time of start and if necessary provide means of admission. A copy of the programme or start sheet shall be sent to the Region issuing the permit for the event and to each race official. Programmes for competitors shall be made available free of charge.

## 20.6 Local Bye-Laws and Inconvenience to the Public

20.6.1 The organiser of a road race shall ensure that his race, and the arrangements for the race, do not contravene the law of the land, or any local bye-laws, relating to noise, litter, street collections, bill posting, display of banners, programme selling, or the like.

- 20.6.2 The starts and finishes of road races shall be sited so as to cause the least possible inconvenience to other road users.
- 20.7 Feeding Stations**
- 20.7.1 Organisers shall announce the location of feeding stations prior to the start of an event, or in stage races immediately prior to the commencement of each stage, and no other feeding stations shall be set up, except as appointed by the organiser.
- 20.7.2 An official shall be appointed at each feeding station to ensure that it is left in a clean condition after the event.
- 20.8 Race Controls**
- 20.8.1 There shall be a control point at the start of road and circuit races where riders shall sign on for a race, hand in their licences, collect their race numbers, have their gears checked (where necessary) and receive instructions and information about the race. Team Managers shall also sign on, indicating the riders in their charge, and hand in their licences. Similarly there shall be a control point at the finish of a road or circuit race where riders shall hand in their race numbers and recover their licences. The organiser shall ensure that the control points for a road race do not cause obstruction of the highway or annoyance to passers by.
- 20.8.2 Organisers shall have at the start control point of a road or circuit race a signing-on sheet in duplicate which shall be signed by all competitors at least 20 minutes before the advertised time of start of the event. The signing-on sheet shall show the name, club, and licence number of each rider. The following heading shall appear on every signing-on sheet.
- 20.8.2.1 I agree to abide by the B.C.F. Technical Regulations and understand and agree that I participate in this race entirely at my own risk, that I must rely on my own ability in dealing with all hazards, and that I must ride in a manner which is safe for myself and all others. I am aware that when riding on a public highway the function of the marshals is only to indicate direction and that I must decide whether the movement is safe. I agree that no liability whatever shall attach to the promoter, promoting club, race sponsor, the British Cycling Federation or any race official or member of the British Cycling Federation or member of the promoting club in respect of any injury, loss or damage suffered by me in or by reason of the race, however caused.
- 20.8.2.2 The original signing-on sheet shall be attached to the Chief Commissaire's report and filed by the Region issuing the permit with all other documents relating to the race in question. The report and signing-on sheet shall be retained by the Region for a period of six years.
- 20.9 The Start**
- 20.9.1 Riders shall line up not more than two abreast unless it is a closed circuit criterium or the start be off the public highway when the Chief Commissaire shall use his discretion. Riders shall start with one foot on the ground and pushers/holders shall not be permitted.
- 20.9.2 The Chief Commissaire or person appointed by him will signal the start of the race by lowering a flag.
- 20.10 Race Vehicles and First Aid**
- 20.10.1 All road races (except those taking place on a circuit of 5 km or less) shall be preceded by a vehicle displaying a sign on which shall be inscribed in bold lettering the words CAUTION CYCLE RACE APPROACHING and that a stand-by vehicle and sign shall be available to cover the second group of riders, at the discretion of the Chief Commissaire, in the event of a split in the field.
- 20.10.2 The organiser of a road race shall provide suitable motor vehicles for the use of the Commissaires except where a closed circuit criterium is 1 km or less. The Commissaires may use their own vehicles by arrangement with the organiser and for which the organiser will reimburse the expenses of the Commissaire immediately following the event.
- 20.10.3 All official motor vehicles connected with a road or circuit race shall have a sign showing to the front with the words BCF CYCLE RACE OFFICIAL and a sign showing to the rear with the words CAUTION CYCLE RACE IN PROGRESS, both inscribed in bold lettering.
- 20.10.4 Where a vehicle, not being an official vehicle, but connected with a rider or riders in a race, immediately precedes or follows a race without the permission of the Chief Commissaire, or where in the opinion of the Chief Commissaire such vehicle is adversely affecting the progress of a race, the rider or riders concerned shall be withdrawn from the race.
- 20.10.5 The organiser of any road, circuit or track event shall arrange provision of one or more qualified first-aiders.
- 20.10.6 The First Aider shall travel in an independent vehicle behind the race. Normally behind the last remaining large group on the road, though the final positioning of this vehicle shall remain at the discretion of the Chief Commissaire.
- 20.11 Race Service**
- 20.11.1 Subject to the approval of the Board or the Region concerned and with the agreement of the Organiser and Chief Commissaire, representative, trade and club teams consisting of at least three riders starting the event shall each be permitted one service vehicle to follow the race, such vehicles shall be provided by the team. The driver and mechanic shall be full members of the Federation and one of the occupants of the vehicle must be the holder of a Team Manager's licence.
- 20.11.1.1 Riders may receive service from the technical personnel of their team or from a neutral service vehicle.
- 20.11.1.2 Whatever the position of a rider in the race, he may only receive such service at the rear of his bunch and on the left hand side of the road.
- 20.11.1.3 The greasing of chains from a moving vehicle is forbidden
- 20.11.1.4 Persons riding in service vehicles shall not reach or lean out of the vehicle whilst it is in motion.
- 20.11.1.5 If motorcycle service is permitted, the only service equipment to be carried shall be spare wheels.
- 20.12 Competitors**
- 20.12.1 The onus of keeping to the course rests with the rider.
- 20.12.2 All competitors must observe the law of the land in relation to road travel, and exercise extreme care when contesting sprints or primes. All forms of traffic signals and direction indicators must be obeyed. Competitors who ride dangerously shall be liable to disqualification and may be subject to further disciplinary action as provided for by T.R. 19. Race officials must not attempt to regulate other traffic on the road.
- 20.12.3 If a breakaway group, or individual, having a lead of more than 30 seconds, is halted by a closed railway level crossing and is caught by the main field, the Chief Commissaire shall ensure that the time is recorded accurately and he shall cause the main field to be halted for an identical period of time. When only the main field is halted by a closed railway level crossing the Chief Commissaire shall take no action to halt any breakaways which have passed through the crossing.
- 20.12.4 A competitor in a road or circuit event when lapped must, unless otherwise instructed by the Chief

- Commissaire, retire from the race and report to the control point at the finish of the race.
- 20.12.5 Where a lapped rider is allowed to continue, he shall not give pace or shelter to a rider by whom he has been lapped. Otherwise riders in a road or circuit race may take pace or shelter from each other, but not from any other vehicle.
- 20.12.6 Any rider who passes the first lead vehicle in an event may be liable to disqualification.
- 20.13 Competitors may exchange among themselves machines, food, drink, wheels, tyres, tools and pumps. Otherwise no food, drink or equipment may be handed to a competitor otherwise than by a person on foot. The use of breakable vessels of any kind is prohibited.
- 20.14 Riders who have finished must proceed at once to the control point at the finish, hand in their numbers, and collect their licences. The Finishing Commissaire shall cause an announcement of the official placings to be made at the control point as soon as is practicable by the posting up of a written result.
- 20.15 Race Control Flags and Placards**
- In all open events flags shall be displayed at the following points:
- 20.15.1 The National Flag at the starting point.
- 20.15.2 A black and white chequered flag to denote the finish.
- 20.15.3 A yellow flag 200 metres from the finish.
- 20.15.4 A white flag at every prime point.
- 20.15.5 A green flag with a white border 200 metres from every prime point.
- 20.15.6 A blue flag at the commencement of each hill prime.
- 20.15.7 A red flag at all danger points.
- 20.15.8 A red and white chequered flag at the start of a neutralised area.
- 20.15.9 A red and white chequered flag with a wide black border at the finish of a neutralised area.
- 20.15.10 A black flag may be shown to stop the race on the instructions of the commissaire.
- 20.15.11 All flags, with the exception of the National Flag, shall be one metre square.
- 20.15.12 A placard not less than 500 millimetres square, bearing the words ONE KILOMETRE TO FINISH shall be placed at that point.
- 20.15.13 A placard not less than 1 metre square, bearing the words CAUTION CYCLE RACE FINISH AREA shall be placed 250 metres after the finish line in a position to be seen by all traffic approaching the finish line from the opposite direction to the riders excepting closed circuit criteriums.
- 20.16 Incidents, Accidents and Complaints**
- 20.16.1 Any competitor involved in an accident during a road race must within three days of the accident report it, or have it reported on his behalf, to the Region issuing the permit for the race. The Region shall report the accident to Headquarters within seven days of the race.
- 20.16.2 Where a rider or official in a road race receives a summons as the result of any incident alleged to be in connection with the race he shall forward the summons immediately to the Region issuing the permit for the race.
- 20.16.3 Where a rider or official in a road race is convicted as the result of an incident in connection with the race he shall be suspended and dealt with under the provisions of T.R. 19 unless in the meantime the incident has already been reported and dealt with under that Regulation.
- 20.16.4 Police co-operation is desirable for all events and organisers and others shall avoid giving grounds for criticism and adverse relations. Any complaint received from the Police in respect of a road race must within three days of its receipt be communicated to the Region issuing the permit for the race, which shall deal with the complaint immediately.
- 20.17 Race Results**
- 20.17.1 The organiser of a road race shall within 20 days of the event send a copy of the race results to the Region issuing the permit.
- 20.17.2 The Chief Commissaire shall complete and forward the official BCF Result card for each event he serves on to BCF Headquarters to arrive no more than two days after the completion of that event.
- 20.18 Road or Closed Circuit Criterium Series.**
- 20.18.1 The provisions of T.R. 20 inclusive shall apply to a road or closed circuit criterium series and to each event in the series, except that entries and the entry fee shall be for the whole series and not for individual events therein.
- 21 STAGE RACES**
- Stage races will be conducted under regulations as set out below in addition to the normal technical regulations, unless the organiser specifies to the contrary on the entry form or prospectus and issues his own special regulations to all competitors and all officials prior to the event. Such special regulations may only deal with items which are not already covered by the BCF Technical Regulations.
- 21.1 Penalties (either time, disqualification or fines, as appropriate) may be imposed at the discretion of the Chief Commissaire upon individual competitors or teams. See T.R. 12.
- 21.2 In the event of any accident, mechanical trouble or puncture occurring within the last three kilometres of any stage, the competitor(s) concerned will be credited with the finishing time of the last competitor of the group he/they were with at the time of the incident. This providing that the finishing line is crossed within the time limit (T.R. 21.13).
- 21.3 In timing stage finishes each rider in a group will be awarded the time of the leading rider at the line save that, where the timekeeper can ascertain a gap of one full second or more between riders, the riders after that gap shall be timed as another group and given the time of the leading rider in the group. Where photo finish is in use the same principle will apply.
- 21.4 Individual General Classification shall be calculated as the total time taken by the rider to complete each stage of the race plus penalties and less bonuses.
- 21.5 Team Classification shall be calculated as follows: for stage and/or overall classification, the times of the best three riders of a team on any stage added together (plus penalties). Team times for each stage will be added together to calculate the Team General Classification.
- 21.6 In 21.4 above, the winner of the competition shall be the rider having the lowest net time. In the event of two or more riders having equal times, the order shall be determined by adding together the places obtained on each stage, the rider having the lowest number taking precedence. Should two or more riders still be equal, then the places on the final stage shall decide the order.
- 21.7 In 21.5 above, the winner of the competition shall be the team having the lowest net time. In the event of two or more teams having equal times, the order shall be determined by the number of stage wins obtained by each team and then by the number of second places and so forth.

- 21.8 A rider who does not complete a stage of the race or is disqualified or finishes outside the time limit shall be excluded from the remainder of the race.
- 21.9 Time bonuses for stage finishes, unless specified otherwise in the event regulations as issued by the organiser, shall be 1st - 30 sec; 2nd - 20 sec; 3rd - 10 sec. (Time bonuses for intermediate sprints may be awarded if announced previously). Time bonuses shall not be awarded for time trial stages.
- 21.10 Where a stage finishes on a track, the finishing time will be taken at the entrance to the track where the yellow flag will also be placed. Riders will enter the track and pass the finishing post once before completing a further full lap. Stage positions shall be determined as the order in which the riders cross the finishing line.
- 21.11 Where a stage finishes on a circuit of two kilometres or less, the time shall be taken at the entrance to the circuit.
- 21.12 Where a stage finishes on a circuit of more than two kilometres but less than five kilometres, the time shall be taken at the first crossing of the finishing line.
- 21.13 A time limit of 20% of the stage winner's time shall apply on each stage. This limit may be increased at the discretion of the Race Jury.
- 21.14 Organisers shall provide a minimum of one neutral service vehicle for all stage races.
- 21.15 Race organisers may accept substitute riders in races for teams of 3 or more riders. These substitutions may take place up to one hour before the start time, after which no further substitutions may be effected. No reserves shall be permitted for events invoking this regulation. Application to invoke this regulation must be made to the permit issuer at least six weeks prior to the date of the event.
- 22 TIME TRIALS**
- 22.1 All events will be held under a permit issued in accordance with the Technical Regulations.
- 22.2 Permission to hold the event should not be sought from the Police Authority but appropriate notification given to the Police as required by section 3 of the Cycle Racing on Highways Regulation 1960.
- 22.3 The maximum number of competitors shall be as approved by the Region, up to a maximum of 120.
- 22.4 Competitors not ready to start at the stated time must report to the timekeeper when ready. The Chief Commissaire shall use his discretion as to when such competitors shall start. These competitors shall only lose the time between their original starting time and their time of reporting to the timekeeper. No competitor shall be allowed a re-start.
- 22.5 Competitors shall be started at intervals of not less than one minute.
- 22.6 Competitors must ride entirely alone and unassisted. They must not ride in company with, nor take shelter from, any other rider or from any vehicle on the road. If one competitor overtakes another he must pass as widely as possible and no shelter must be given or received. The onus of avoiding riding in company shall be upon the rider overtaken who must drop back by at least 25 metres. Competitors when dismounted must wheel or carry their machines without assistance whilst covering any portion of the course.
- 22.7 Competitors shall not be accompanied, followed, or in any way encouraged, by a helper in or on a motorised vehicle whilst such a vehicle is moving except that the Board may permit each rider to be followed by a single motor vehicle in certain specified events. Such vehicles must carry a bold identification name and/or number to the front and rear of the vehicle.
- 22.8 Any permitted following vehicle shall carry an assistant commissaire/observer approved by the Chief Commissaire. Such following vehicle must remain at least 20 metres behind the competitor and is not permitted to pass the competitor or draw alongside. In the event that service is required, the competitor must come to a complete stop.
- 22.9 When one competitor is catching any permitted vehicle following the slower competitor, the latter vehicle must drop back behind any permitted vehicle following the faster competitor as soon as the distance between the two competitors is 100 metres. When the faster competitor catches the slower, the vehicle following the faster competitor must not pass the overtaken competitor until the gap is 60 metres. If the gap should subsequently close, the vehicle must drop behind the second competitor.
- 22.10 Any contravention of these regulations by drivers/occupants of permitted following vehicles will result in disciplinary action being taken against those persons and the competitor concerned.
- 22.11 All competitors shall wear properly affixed protective headgear which should be of a hard/soft shell construction (see T.R. 8.6.1). Junior riders' gears shall be restricted as per T.R. 3.3
- 22.12 The use of loudhailers or speaker systems for the purpose of encouraging riders is not permitted.
- 22.13 All relevant B.C.F. Technical Regulations appertaining to road races must be observed in addition to the aforementioned regulations.
- 22.14 Where permitted by the local Police Authorities flashing/rotary amber beacons shall be fitted where possible to ALL following race vehicles. The only exception to this shall be motorcycle officials.
- 22.15 With the exception of National Championships the minimum licence status criteria for participants in Time Trials and Team Time Trials shall be that of Provisional. The minimum membership status shall be that of Silver.
- 23 TEAM TIME TRIALS**
- 23.1 Regulations for Time Trials shall apply to Team Time Trials as appropriate.
- 23.2 Teams shall be of two, three or four riders and all teams in any one event shall consist of an equal number of riders. Teams shall be started at intervals of not less than two minutes for teams of two and not less than three minutes in other cases.
- 23.3 Incomplete teams may start but (except teams of three starting in a competition for teams of four) shall not qualify for an award.
- 23.4 All riders in each team shall be attired in jerseys of similar colour and design.
- 23.5 Each competitor must be issued with a separate number with the numbers of each team including reserves being numbered consecutively.
- 23.6 Teams may nominate one reserve in the case of teams of three and two reserves in the case of four. The names of all reserves shall appear on the start sheet.
- 23.7 The normal formation of a team shall be single file with the minimum amount of echelon to allow a view ahead for each rider. In passing other teams or vehicles, teams shall always be in single file.
- 23.8 No teams or members of teams shall take shelter from other vehicles or members of other teams. If one team overtakes another the onus shall be upon the overtaken team to avoid such racing by dropping back at least 25 metres. An overtaking team must pass on the outside leaving a reasonable gap between itself and the other team.

- 23.9 Each rider in each team shall be separately responsible for keeping a continuous look-out ahead and obeying all laws, road signs and Police signals
- 23.10 The time of a team shall be that recorded by the last member of the complete team to finish, except that in teams of four the time shall be that recorded on the third member of the team to finish who shall have completed the course. Awards won by a team shall be given to all starting members of that team and no special award shall be given to any individual member of a team.
- 23.11 Competitors shall not be accompanied, followed, or in any way encouraged, by a helper in or on a motorised vehicle whilst such vehicle is moving except that the Board may permit each team to be followed by a single motor vehicle in certain specified events. Such vehicles must carry a bold identification name and/or number to the front and rear of the vehicle. At no time may a following vehicle approach closer than 20 metres behind the last man of the team or the third rider of a four man team if the fourth rider has been dropped.
- 23.12 Any exchange of food, drink and equipment may only take place among members of the same team.
- 23.13 Pushing between team members is not permitted.

## **24 TRACK RACING**

### **24.1 Officials**

- 24.1.1 The officials at a track meeting shall consist of (as necessary) a Chief Commissaire, Assistant Commissaires, Timekeepers, Starters, Clerks of the Course, Recorder, Gear Checkers {where necessary to ensure compliance with T.R. 3.3} who must be either associate, affiliated, private or life members of the Federation. Licence Steward, Lap Scorers, Stewards, and Pacing Marshals may also be appointed.
- 24.1.2 Chief Commissaires for track events listed in T.R. 15.2.1. and all designated major track events shall be appointed by the Board.

### **24.2 Officials Duties**

- 24.2.1 The Chief Commissaire shall deal with all questions relating to the conduct and result of a race. He shall instruct the other officials in their duties and, where necessary, delegate authority to them. He shall decide on protests, levy fines on riders, and act as he thinks fit in case of misconduct by competitors or officials, if necessary by disqualifying or relegating any such competitor or official for the whole or part of the track meeting as he may determine without a protest necessarily being lodged. In all matters the Chief Commissaire's decision shall be final, except that written protests may be submitted in accordance with the procedure set out in T.R. 16.11.1.
- 24.2.2 Assistant Commissaires at track meetings shall have such powers and carry out such duties as the Chief Commissaire directs.
- 24.2.3 The Clerk of the Course shall call over the names of the competitors, see that they are on their appointed marks or positions, are properly clothed, their numbers properly exhibited, and that their machines conform to the provisions of T.R. 3. The Clerk of the Course will tell the Starter when he is satisfied that a heat or race is ready to start.
- 24.2.4 The Starter, when it has been reported to him by the Clerk of the Course that the competitors are ready, shall sound a warning whistle and then effect the start by firing a pistol shot. In the case of a false start the Competitors shall be called back by the Starter, on the instructions of the Clerk of the Course, firing a second pistol shot.
- 24.2.5 A Gear Checker shall inspect all relevant cycles and spare wheels, where necessary to ensure compliance

with T.R. 3.3. It is the responsibility of the competitor and/or the parent or guardian in the case of under 18s, to ensure that for every race held under these regulations his cycle is in a safe condition.

### **24.3 National Track Championships Officials**

In the case of the National Hard Track Championships when held as a multiple day series the positions of Chief Commissaire and Assistant Commissaires will be incorporated within a panel of Commissaires presided over by a Chairman appointed by the Board.

### **24.4 Handicapping**

- 24.4.1 The appointment and re-appointment of handicappers shall rest with Regions.
- 24.4.2 Applicants for appointment must be members of the Federation and submit evidence of their experience of handicapping, together with a recommendation from a club affiliated to the Federation.
- 24.4.3 Applicants for appointment should ordinarily have worked for a year handicapping under the guidance of an appointed handicapper before submitting an application for appointment.
- 24.4.4 Regions must notify the appointment or re-appointment of handicappers to the Competition Director of the Federation, and his application must be made not later than 20 days before the Region Annual General Meeting.
- 24.4.5 All open handicaps at track meetings must be handicapped by an appointed handicapper.
- 24.4.6 An appointed handicapper may charge fees as may be agreed upon between him and an organiser.

### **24.5 General Administration**

#### **24.5.1 Entries**

- 24.5.1.1 Entries for open events at track meetings must be made on the entry forms shown in the Appendices to these Regulations.
- 24.5.1.2 This form shall enable the entrant to show details of the last event he has ridden at each of the distances entered, his last three performances in handicap events, and the last handicap event in which he won a prize. Results of club events shall not be given unless the entrant has no other performances to show.
- 24.5.1.3 The entry form must be signed by the entrant and be accompanied by the appropriate entry fee, failing which the entry shall be void.
- 24.5.1.4 An organiser shall ensure that all entries for open or confined events at his track meeting are available at the meeting for the inspection of the Chief Commissaire if required.
- 24.5.1.5 Rejected entries, for whatever reason, shall be returned within three days of the closing date for the track meeting.
- 24.5.1.6 The standard closing date for all track events, other than Track Leagues, shall be 20 days unless otherwise indicated.
- 24.5.1.7 Track event closing dates, if other than standard, shall be printed in the Track Calendar in the Federation's Annual Handbook.
- 24.5.1.8 The entry fee for one event at a track meeting shall not be less than the minimum charge for admission to the track. For each subsequent event the entry fee shall be decided by the organiser.

#### **24.5.2 Tickets**

- 24.5.2.1 The organiser shall send a competitor's ticket to each accepted entrant not later than seven days before the track meeting in question.

- 24.5.2.2 Tickets for entrants being members of the same club may, with their agreement, be sent to a named official of that club.
- 24.5.2.3 The ticket shall admit the holder to the meeting and show the venue, date and time of start of the meeting; and where heats are being held prior to the advertised time of start of the meeting, the time of start of such heats shall also be shown on the ticket.
- 24.5.2.4 The organiser of a track meeting shall at least three days prior to the meeting send to the Region issuing the permit for the meeting two tickets of admission and, where possible, two copies of the programme for the meeting.
- 24.5.3 Signing On**
- 24.5.3.1 On arrival at the track, a competitor shall be given, without charge, a programme of the meeting.
- 24.5.3.2 There shall be a control point at a track meeting where the riders shall sign on, hand in their licences, and collect their race numbers.
- 24.5.3.3 Team Managers shall also sign on, indicating the riders in their charge, and hand in their licences.
- 24.6 General Track Racing Rules**
- 24.6.1 In track racing, Juniors may compete with all other categories and without gear restrictions.
- 24.6.2 A competitor qualifying in a preliminary heat must ride in the next round unless he has the sanction of the Chief Commissaire to abstain, when the Chief Commissaire may allow the next in that heat to compete in his stead.
- 24.6.3 No competitor shall attempt to pass inside the sprinters line when a preceding rider is on the line or inside it.
- 24.6.4 A competitor overtaking another must pass on the outside unless the rider who is passed be dismounted, or has retired, or is riding wide. Before taking ground in front of another rider there must be a clear length between his own and the other rider's machine. Riders must allow room for their opponents to pass on the outside. Any competitor infringing this regulation or being otherwise guilty of foul or unfair riding shall be liable to disciplinary action.
- 24.6.5 Any rider who fails to take up the chase, when a rider or riders break away, may be deemed to be failing to defend his chances, and be liable to disciplinary action.
- 24.6.6 A lapped rider shall not give pace or shelter to a rider by whom he has been lapped. The Chief Commissaire shall have complete discretion to decide when a rider has been lapped.
- 24.6.7 Competitors may dismount during a race at their pleasure, and may run with their machines in order to finish the race.
- 24.6.8 In the event of a dead heat in the final of National or Region Championship events under 1 kilometre (500m for Women, Junior and Under 16's) the riders dead-heating shall re-ride, at 1 km and over they shall jointly hold the title and each receive the appropriate award.
- 24.7 Handicaps**
- 24.7.1 Two copies of the completed event programme should also be forwarded to the National Handicapper.
- 24.7.2 The distance of handicaps under 1 kilometre must be stated in metres on all advertisements, entry forms and programmes. In all races where the distance of qualifying heats varies from the distance of the final, the full details shall be given in the prospectus of the meeting. All qualifying heats shall be over the same distance.
- 24.7.3 Beginners marks in open events shall be 10% of the distance of the event. I.e. 50 metres in 500m
- 24.7.4 A competitor winning a prize in an open handicap after entering for another handicap shall be, unless already considered by the handicapper, subject to a 10, 5 or 2½% penalty for first, second or third places, fractions of metres being ignored.
- 24.7.5 He must report any such win immediately in writing to the organiser of the meeting, who shall inform the handicapper.
- 24.7.6 The handicapper shall notify the organiser whether he had considered such win, or if a penalty shall be applied on the day.
- 24.7.7 Prior to competing the competitor must also notify the Chief Commissaire of such win or wins otherwise he may be disqualified and liable to suspension.
- 24.7.8 Two or more wins on one day shall incur one penalty only. Wins on subsequent days shall carry additional 10% penalties calculated from the actual mark started from.
- 24.7.9 Handicappers may impose penalties in subsequent events for wins at the same meeting, but only if so stated in the programme. Where a handicapper has reserved the right to impose penalties in subsequent events for wins at the same meeting he shall have the right to exercise his discretion as to the new mark allotted.
- 24.7.10 When track meetings are postponed competitors who win open handicaps during the intervening period shall be subject to the above penalties.
- 24.7.11 Any rider competing in three consecutive track handicaps but failing to be placed in the first three, shall receive a lift of 10%, fractions of meters being ignored.
- 24.7.12 A handicapper may adjust a rider's mark in the light of special knowledge.
- 24.7.13 A rider may be penalised at a meeting by the handicapper and/or the Chief Commissaire for an infringement of these Regulations. The Competition Director must be informed of such a penalty.
- 24.7.14 If a rider gains an award from such a penalty mark, that mark, reduced by the penalty for being placed, becomes that rider's new mark.
- 24.7.15 Riders marks shall not be changed except in accordance with these Regulations.
- 24.7.16 Each competitor shall be allowed an attendant to push off, but no part of the body of the pusher or attendant must touch the track in front of the rider's mark or starting line, otherwise the rider shall be liable for disqualification.
- 24.7.17 Each competitor must start from his proper mark and in default may be disqualified but, with the consent of the Chief Commissaire, he may start from a mark behind the one allotted him.
- 24.7.18 In starting, the foremost part of the machine should be in line with the competitor's mark and on banked tracks near the base of the banking whenever possible or otherwise as the Clerk of the Course may decide.
- 24.7.19 Where more than one competitor starts from the same mark, lots may be drawn to decide their positions counting from the inside of the track.
- 24.7.20 A competitor starting before the signal may be put back at the discretion of the Clerk of the Course for a distance not exceeding 10% of his handicap allowance, and on a repetition of the offence shall be disqualified.
- 24.8 Sprint**
- 24.8.1 The Chief Commissaire shall prepare a formula showing the composition of the heats, if not already shown in the programme, repechages and other heats resulting therefrom.

- 24.8.2 The starting position of each rider shall be decided by the drawing of lots. The rider drawing the inside position shall lead until crossing the finishing line at the end of the first lap or until the bell to indicate one lap to go, whichever is the sooner, unless an obligation to lead is taken over by another rider. This distance shall be covered at a minimum speed of walking pace.
- 24.8.3 Should the race be on a best of three basis each rider shall lead one race, and a further draw shall be made should a deciding race prove necessary.
- 24.8.4 The start of a race shall be given by a pistol shot or whistle. A further pistol shot or whistle shall indicate the stopping of a race.
- 24.8.5 Once the start has been adjudged valid by the Starting Commissaire/Clerk of the Course, the race shall only be stopped in the case of a puncture, a fall or the breakage of an essential part of the bicycle. In the case of an accident deemed to be valid, the Chief Commissaire shall decide whether to allow a new start, with or without the rider deemed responsible, or whether to consider the result as having been established.
- 24.8.6 The insufficient tightening of a component cannot be considered a valid reason for stopping a race.
- 24.8.7 A restart shall be declared if, during a standstill, one of the competitors draws back by more than 20 cm or if a competitor jumps his wheel. In such a case the competitor at fault shall lead off in the restart.
- 24.9 Tandem Sprint**
- 24.9.1 In no case may more than 3 tandems be lined up together.
- 24.9.2 The event shall be organised in accordance with the Sprint Regulations.
- 24.10 Individual Time Trial**
- 24.10.1 An appointed holder or mechanical starting gate shall support the rider at the start. The rider must not be swung or pushed.
- 24.10.2 The start shall be given by a pistol shot, whistle or electronic device.
- 24.10.3 Once the start has been adjudged to be valid by the Starting Commissaire/Clerk of the Course, should a rider be forced to stop due to a puncture, a fall, or the breakage of an essential part of the bicycle, he shall wait until five other riders, or all riders if less than five, shall have started before trying again.
- 24.10.4 No rider shall make more than three attempts to establish a time.
- 24.10.5 The insufficient tightening of a component cannot be considered a valid reason for stopping a race.
- 24.10.6 The event shall be organised in accordance with Technical Regulations -Records.
- 24.10.7 Should two or more riders record the same time, they shall be placed equal.
- 24.11 Individual Pursuit**
- 24.11.1 A preliminary round may be held to establish the fastest riders to make up the subsequent heats.
- 24.11.2 In the preliminary round only the time of each rider shall be considered and all riders, including those caught, will continue to cover the full distance to record a time.
- 24.11.3 Riders who are caught must not take pace or shelter from the leading rider.
- 24.11.4 Riders shall take up position on the inside of the track diametrically opposite each other.
- 24.11.5 In multi-station pursuits riders shall be spaced around the track at equal distances.
- 24.11.6 A lap board and bell shall be set up at each finishing point.
- 24.11.7 The start shall be given by a pistol shot, whistle or audible electronic device. A further pistol shot or whistle shall indicate the stopping of a race.
- 24.11.8 An appointed Holder or mechanical starting gate shall support the rider at the start. The rider must not be swung or pushed.
- 24.11.9 During any preliminary round a false start shall be signalled if, within the first 30 metres, a rider suffers a puncture, a fall, or the breakage of an essential part of the bicycle, and the riders shall start again.
- 24.11.10 Should the incident occur after the first 30 metres, the rider concerned shall drop out but the other rider(s) shall continue to complete the distance.
- 24.11.11 The restart by the rider concerned shall take place after all other preliminary heats have been run off.
- 24.11.12 The insufficient tightening of a component cannot be considered a valid reason for stopping a race.
- 24.11.13 In heats following the preliminary round, losers shall be eliminated.
- 24.11.14 In making up heats the Chief Commissaire shall match fastest against slowest, second fastest against second slowest and so on.
- 24.11.15 In all heats a rider who catches his opponent shall continue for the full distance to record a time.
- 24.11.16 A rider shall be considered caught when the pursuer draws level with him.
- 24.11.17 Restarts**
- In all heats should either rider suffer an accident as described in T.R. 24.11.9, the following procedure shall apply:-
- 24.11.17.1 During the first  $\frac{1}{4}$  of the race: the race shall be restarted.
- 24.11.17.2 Between  $\frac{1}{4}$  and  $\frac{3}{4}$  distance: the leading rider shall restart on the last half-lap line he passed. The other rider at a distance behind the other half-lap line equivalent to time gap behind the leading rider at the last half-lap time.
- 24.11.17.3 After  $\frac{3}{4}$  distance the result at the moment of the accident shall stand. The leading rider shall continue, if able, to complete the full distance. If unable to continue, his time for the full distance shall be calculated for the purpose of seeding the next round.
- 24.11.18 In the case of a dead heat at the finish, the riders shall be placed according to the best time recorded for the last lap, followed by the penultimate lap, etc.
- 24.12 Team Pursuit (4 Man Teams)**
- 24.12.1 The race shall be held in accordance with the Regulations for Individual Pursuit, except as detailed in the following clauses.
- 24.12.2 If a mechanical starting gate is used, it shall support the rider on the inside of the starting formation.
- 24.12.3 During any preliminary round should a false start be signalled after the first  $\frac{1}{2}$  lap the team may either drop out or continue with 3 riders.
- 24.12.4 Should the team drop out it must do so within one lap of the incident occurring.
- 24.12.5 If there are less than 3 riders to continue a restart shall be allowed.
- 24.12.6 Teams which are reduced to less than 3 riders shall be eliminated.
- 24.12.7 Pushing between team members is not permitted.
- 24.12.8 Teams shall nominate a maximum of 6 riders.

- 24.12.9 The composition of a team may be altered for each round by selection from nominated riders.
- 24.12.10 In the event of accident/injury, substitution may similarly be made during a round but only with the approval of the Chief Commissaire.
- 24.12.11 Times shall be recorded as for the third rider in each team.
- 24.12.12 A team shall be considered caught when the first rider of the leading team (consisting of at least three riders riding together) is within one metre of catching their opponent team where all four riders are together or where the team to be caught has three or less riders together, is within one metre of the third rider.
- 24.12.13 In the event of any rider interfering with or impeding the other team, his team shall be disqualified.
- 24.12.14 In team events a team may receive one restart throughout the competition where their ride is abandoned due to the insufficient tightening on a component.
- 24.13 Points Race**
- 24.13.1 The winner shall be the rider with the highest number of points gained. For tracks under 250 metres laps gained or lost on the main bunch are 15 points, for tracks between 250 and under 400 metres 20 points and for tracks over 400 metres, 25 points. This shall apply to points races of 15kms or more. In shorter races, half of the above points shall apply.
- Note: Internationally, a points race is now a race decided on points, and a Madison is a race decided by points and lap.)*
- 24.13.2 Where two or more riders are equal on points the places in the final sprint shall determine the winner.
- 24.13.3 Sprints shall take place on pre-determined laps with the first 4 riders over the line gaining 5, 3, 2, 1 points respectively.
- 24.13.4 A rider or riders are considered to have lapped the field when they catch up with the last rider in the main group.
- 24.13.5 Any rider or riders lapping the field shall cease to lead the field. The lead is then taken over by the rider or riders in front of the field on the track or failing that by the rider leading the main group. These riders shall be the leaders on the track but the race leader shall be the rider who has covered the greatest number of laps.
- 24.13.6 A whistle or bell will indicate the start of a sprint lap and must always be for the leader(s) on the track.
- 24.13.7 A rider lapped during a sprint lap will not qualify for points in that particular sprint.
- 24.13.8 The final lap shall be that of the race leader.
- 24.13.9 Lapped riders need not complete lost laps and shall be classified in accordance points gained. Any rider who retires from the race shall not be included in the result, regardless of the number of points gained.
- 24.14 Madison**
- 24.14.1 Teams shall be of two or three riders wearing the same colours and number.
- 24.14.2 There must be one rider of each team in the race at all times.
- 24.14.3 Riders may relieve each other at any time during the race.
- 24.14.4 Changing shall take place below the stayers line and as near to the inside edge of the track as practicable.
- 24.14.5 Relieved riders must take up a position outside the stayers line as soon as it is safe and practicable.
- 24.14.6 Changing shall be by one rider drawing level with the other and touching to denote relief.
- 24.14.7 The touch may be a push or handsliding.
- 24.14.8 The winners of the race shall be the team which gains the most laps on the other teams.
- 24.14.9 If two or more teams are on the same lap, the result shall be determined by the team which has won the most sprint points during the race.
- 24.14.10 Should there be an equality of laps and points, the winners shall be the best placed team in the final sprint.
- 24.14.11 The race shall end when the leading team has completed the distance.
- 24.14.12 Lapped riders need not fulfil lost laps, and shall be placed as so many laps behind the winners.
- 24.14.13 At pre-determined times during the race there will be sprints for points, with the first four teams over the line gaining 5, 3, 2 and 1 points respectively.
- 24.14.14 A whistle shall be blown to indicate one lap to go before a sprint.
- 24.14.15 A bell will be rung at the start of the last lap.
- 24.14.16 Teams that rejoin the field, after gaining or losing laps, shall be eligible for sprint points.
- 24.14.17 Should one member of a team suffer a puncture or mishap, he will be allowed to rejoin the race. However, his partner should rejoin the race within two laps being covered by the field from the point at which the incident occurred. The Chief Commissaire will pair the rider in the race with another team which is at the same relative position in the race. The rider will ride 'in and out' with the nominated member of the other team until his partner rejoins the race.
- 24.14.18 Any team retiring from the race shall inform the Chief Commissaire immediately.
- 24.14.19 Teams may be disciplined by losing points, losing laps or disqualification.
- 24.14.20 The Chief Commissaire may neutralise a race should it be considered necessary to do so, as in the case of a crash involving several teams or the track becoming unsafe or impracticable for use.
- 24.14.21 The Chief Commissaire may terminate a race before the full distance should it be considered essential to do so.
- 24.14.22 The Chief Commissaire may withdraw teams who fall too many laps behind or who, in his opinion, may constitute a danger to other riders.
- 24.15 Motor Pace**
- 24.15.1 Motor Paced Races may be allowed in open meetings subject to permission being given by the Board.
- 24.15.2 Pacing shall be under the direct control of a Pacing Marshal, who may be the Chief Commissaire, who shall have power to order off the track and from the enclosure any pacer disobeying his directions or guilty of misbehaviour.
- 24.15.3 The cycles and motor cycles used shall conform to U.C.I. Regulations.
- 24.15.4 Riders shall draw for order of start and line up in that order, one behind the other, with the leader on the starting line.
- 24.15.5 The pacers shall get into the same order as the riders, and circle the track. Pacers shall wear the number corresponding to position drawn.
- 24.15.6 When the Pacing Marshal is satisfied that riders and pacers are in proper order and ready to start, he will instruct the starter to commence the race in accordance with his instructions.
- 24.15.7 Riders may receive a running push at the start of a race.

- 24.15.8 A false start shall be signalled should a mechanical failure or puncture occur before the riders have joined their pacers.
- 24.15.9 A motor-paced event shall end when the winner has covered the appropriate distance of the event. All other riders shall be placed in the order of their respective time behind the winner if on the same lap or at the appropriate number of laps behind.
- 24.15.10 In a contest embracing a series of events the winner on general classification shall be the rider covering the distance of the series in the fastest cumulative time.
- 24.15.11 A pacer may not ride outside the stayers line except when endeavouring to pass the rider in front.
- 24.15.12 At all times he should leave sufficient space on his right for the other riders to overtake.
- 24.15.13 Any rider attempting to overtake on the inside shall be disqualified.
- 24.15.14 A rider who has been lapped shall allow free passage to that rider should he wish to pass on a subsequent lap.
- 24.15.15 Any disabled pacer or pacing machine may be replaced with the consent of the Pacing Marshal.
- 24.15.16 Application for a pacer's licence will be considered by the Board for:-Class A licence for 500 cc upwards; Class B for motors below 500 cc; Class C for derny type training purposes.
- 24.15.17 All applicants must have complied with the standard laid down in the special regulations issued annually by the Board.
- 24.15.18 Irrespective of differences in the stature of pacers the only clothing that may be worn under the pacing leathers is: Normal underwear of not more than one thickness; A long or short sleeved racing jersey without pockets; A pair of normal racing shorts; A pair of ankle length socks; A pair of racing gloves but not lined or gauntlets; An unpadded one-piece belt free from extensions or flaps. No loose padding whatsoever shall be allowed. All clothing so employed must be tucked into the breeches and secured by means of a belt.
- 24.15.19 Pacers must wear crash helmets of an approved design.
- 25 TRACKS**
- 25.1 Measurements.
- 25.1.1 The circumference of a hard track shall be marked with a 20 mm wide black gauge line with its inner edge set at 20 cm from the inside edge of the track. This line should be white on tracks with a dark surface.
- 25.1.2 The measurement of a track shall be on the inner edge of the gauge line.
- 25.2 Markings
- 25.2.1 On all hard tracks the following markings are obligatory and must be painted on before any track can be approved for competition:
- 25.2.1.1 A 40 mm wide black finishing line in centre of 720 mm wide white line radially across the track at the end of the finishing straight. This line to continue up the safety fence.
- 25.2.1.2 A 50 mm wide red Sprinters line circumferentially round the track with its outside edge 90 cm from the inside edge of the track.
- 25.2.1.3 A 50 mm wide blue Stayers line circumferentially round the track with its outside edge one-third of its width but not less than 2.5 metres from the inside edge.
- 25.2.1.4 A 50 mm wide white 200 metre line positioned radially across the track 200 metres from the finishing line.
- 25.2.1.5 A 50 mm wide red line positioned radially across half the width of the track at the centre of each straight to indicate the finishing point in pursuit races.
- 25.2.1.6 Numbered marks should be placed at the inside edge of the track at every 10 metres forward from the finishing line and similar un-numbered marks at every intervening 5 metres.
- 25.2.1.7 Where the colour of any painted line will not provide a sufficient contrast with the track surface a suitable alternative colour may be used subject to the prior approval of the Board having been obtained.
- 25.3 Grass Tracks**
- 25.3.1 On all grass tracks the finishing line shall be three 25 mm parallel white lines distinctly marked across the track. The two outside lines shall be not more than 300 mm apart and the centre line shall be the finishing line.
- 25.3.2 The inside edge of all grass tracks shall be marked with a 40 mm white line.
- 25.3.3 On all grass tracks where pegs or flags are used to mark the inner boundary of the track, such pegs or flags shall be placed at least 200 mm inside the inner boundary of the track, they shall not be larger than 200 mm by 40 mm by 15 mm, and shall be at an angle with the ground of not more than 45 degrees.
- 25.4 Track Safety Audit**
- 25.4.1 A Region shall cause all permanent tracks within its area to be inspected at intervals of not less than one year in order to ensure that such tracks are safe for racing under these Regulations.
- 25.4.2 Where a Region decides that any track in its area is unsafe for racing under these Regulations, or that illegal betting takes place at the track, the Region may proclaim that no racing under these Regulations shall take place at the track and any Federation member who organises, officiates or rides at the track whilst it is proclaimed shall be in breach of these Regulations.
- 25.4.3 The owner of a track which has been proclaimed under this Regulation may appeal against the decision to the Appeals Board under the provisions of Bye-Law 20.
- 25.4.4 Each Region shall inspect every cycle track in its area and decide the maximum numbers to form a heat in all races thereon, the term heat to include the various stages of a race up to and including the final. The Region Track Secretary shall notify the organiser of a track meeting the maximum number which must not be exceeded. For Under 16s the number of competitors shall generally be half that for other riders.
- 25.4.5 Where possible a safety zone should be provided on the inside edge of all tracks (including grass tracks) with a minimum width of 4m for tracks of 250m or longer, or 2.5m for tracks shorter than 250m. Where the safety zone is between 2.5 and 3m in width, a smooth, unbroken guard wall of at least 90cm in height should be provided on its inner edge.
- During competitions the safety zone must be kept free of any person or piece of equipment (including starting blocks) and any personnel standing in the safety zone shall be kept to a minimum.
- The extent of the Safety Zone shall be clearly defined on all tracks.
- It is recommended that a further safety zone of 2 metres in width be created adjacent to and on the outside of those markers indicating the outside limits of any grass track
- 26 RECORDS**
- 26.1.1 The Board shall adjudicate on claims by citizens of the United Kingdom for track records set up as specified below. Such records shall be known as National Records.

- 26.1.2 The Board shall similarly adjudicate on claims by foreign nationals for track records set up in Federation territory. Such records shall be known as British Allcomers Records.
- 26.2 No claim for a record shall be considered unless the ride has been made :
- 26.2.1 On a track approved by the UCI or measured in accordance with T.R. 25 and the measurement certified by a qualified surveyor.
- 26.2.2 In the presence of an Official Observer appointed by the Board and timed by at least two Chief Timekeepers who have, for the purpose of timing the record or records, used timing devices possessing certificates as specified in T.R. 16.14. Where electronic timing is being used, only one Chief Timekeeper is required.
- 26.2.3 In an open or confined race or a time trial at an open track meeting, or a private time trial for which a permit shall have been granted by the Region within whose territory the attempt is to be made. The permit shall be valid for eight days from the date of issue.
- 26.2.4 Using any gear and equipment restrictions which are in place for the age category or event in question.**
- 26.3 Where any of the records at the times or distances listed in these Regulations remains to be established the Board may set a standard for such record and no claim for the record will be considered unless the standard is equalled or beaten. Otherwise the Board shall adjudicate on claims by riders who consider that their performances should be recognised as records at the said times or distances.
- 26.4 All records may be electronically timed and where so timed shall be to the nearest 1/1000th of a second, in accordance with T.R. 16.14.8.. Where hand held timing devices are used and controlled as described in T.R. 16.14.6, records shall be timed to 1/10th of a second. A 1/10th second beating of an existing record shall establish a new record.
- 26.5 The area of the track inside the gauge line (the black band) shall be made unrideable during record attempts.
- 26.6 At Olympic Games, World Championships, World Cup, Continental and Regional Championships (UCI sanctioned) and National Championships, unpaced standing start records may be approved over distances up to and including 4 kilometres when two riders or two teams start on opposite sides of the track. For all other distances and for record attempts outside such Championships the rider or team shall be alone on the track.
- 26.7.1 In all attempts on standing start records the riders may be held at the start, but shall not receive a push, except that in motor-paced record attempts a running push start may be allowed. The signal for the rider to start shall be the blowing of a whistle, following which the rider has five seconds in which to make his start. The standing start position of the rider's cycle shall be with the front of the front wheel vertically over the starting line. The time shall start upon the rider's front wheel coming into contact with the starting line and finish with the rider's front wheel coming into contact with the finishing line.
- 26.7.2 In all attempts on standing start records a mechanical starting gate may be used in which case the time shall start upon the release of the starting gate.
- 26.8.1 No claim for a record set up outside the aforementioned Championships shall be considered unless ten working days notice of the attempt shall have been given to the Federation Competition Director.
- 26.8.2 Within the notice period the Competition Director shall be responsible for providing an official observer and, where considered appropriate, facilities for an anti-doping control. All other officials must be obtained by the competitor or his helpers. In events covered by T.R. 15.2, the appointed Chief Commissaire shall act as the appointed observer.
- 26.8.3 Records must be claimed by the rider within 14 days of the attempt and upon the Federation's record claim form which will be provided by the appointed Observer present for the attempt. The Board may, at its discretion, extend the time within which a record claim may be made. The original time sheets signed by the timekeepers or the approved operator of a fully automatic timing device as appropriate, and showing lap by lap times shall accompany all record claims . Claims for records broken at the aforementioned Championships shall be supported by the official result communiqué.
- 26.8.4 The Board may procure and use any evidence bearing upon a record claim, and shall retain all documents in connection therewith.
- 26.8.5 No rider shall attempt, or claim, or permit to be published a track record unless under these Regulations, and any rider so attempting, claiming, or permitting, or any official assisting him, shall be in breach of these Regulations. Where a record time or distance is beaten more than once in the same day, only the fastest time or farthest distance shall be recognised as a new record.
- 26.9 The Board may decline to consider any claim it may consider to be contrary to the interests of the sport. Any person improperly claiming or supporting a record shall be in breach of these Regulations.
- 26.10 All motor-paced record attempts shall conform to conditions laid down by the Board.
- 26.11.1 During attempts on the 1 hour record arrangements shall be made to indicate the last lap. To calculate the distance covered in the hour the rider shall, when the time is up, continue for the additional distance and complete the lap. The time taken for the last lap shall be used to calculate the distance covered during the time remaining to complete the hour in accordance with the following formula:  

$$D = \frac{L \times T.R.}{TL}$$
Where:  
D is the additional distance  
L is the length of the track  
T.R. is the time remaining to complete the hour  
TL is the time for the last lap
- 26.11.2 If a recognised incident prevents the rider from completing the last lap, the time of the preceding lap shall be taken to calculate the distance covered.
- 26.12 Records**
- 26.12.1 Men, Bicycles,  
Unpaced standing start, 500 metres, 1, 4, 5, 10 and 20 kilometres, 1 hour (Athletes) and Best 1 Hour, 4 kilometres team (four riders) and 750 metres Team Sprint (three riders).  
Unpaced flying start, 200, 500 and 1000 metres  
Motor paced, standing start, 10, 25 and 50 kilometres, and 1 hour
- 26.12.2 Men, Tandems  
Unpaced standing start, 500 metres, 1, 5, 10 and 20 kilometres, and 1 hour  
Unpaced flying start, 200, 500 and 1000 metres
- 26.12.3 Women, Bicycles,  
Unpaced standing start, 500 metres, 1, 3, 5, 10 and 20 kilometres, 1 hour (Athletes) and Best 1 Hour  
Unpaced flying start, 200, 500 and 1000 metres
- 26.12.4 Women, Tandems  
Unpaced standing start, 500 metres, 1, 5, 10 and 20 kilometres, and 1 hour  
Unpaced flying start, 200, 500 and 1000 metres

- 26.12.5 Junior Men, Bicycles  
Unpaced standing start 1 and 3 kilometres and 4 kilometres team (four riders)  
Unpaced flying start, 200 and 500 metres
- 26.12.6 Junior Women, Bicycles  
Unpaced standing start 500 metres and 2 kilometres  
Unpaced flying start 200 and 500 metres
- 26.12.7 Youth A Male, Bicycles  
Unpaced standing start 500 metres and 2 kilometres  
Unpaced flying start 200 and 500 metres
- 26.12.8 Youth A Female, Bicycles  
Unpaced standing start 500 metres and 2 kilometres  
Unpaced flying start 200 and 500 metres
- 26.12.9 Youth B Male, Bicycles  
Unpaced standing start 500 metres and 1500 metres  
Unpaced flying start 200 metres
- 26.12.10 Youth B Female, Bicycles  
Unpaced standing start 500 metres and 1500 metres  
Unpaced flying start 200 metres
- 26.12.11 Youth C Male, Bicycles  
Unpaced standing start 500 metres and 1500 metres  
Unpaced flying start 200 metres
- 26.12.12 Youth C Female, Bicycles  
Unpaced standing start 500 metres and 1500 metres  
Unpaced flying start 200 metres
- 26.12.13 Disability, Categories LC1-4, CP3 & 4, V.I, H/C A-C Male, Female & Mixed (V.I.)  
Unpaced Standing Start 1 Km, 3Km, 4km, 1 Hour  
Unpaced Flying Start 200m
- 27.4.3 All gears must be checked before each heat, including first, intermediate and final heats and after any exchange of wheels or tyres. It is the rider's responsibility to have this done.
- 27.4.4 Competitions with unlimited gears may be allowed but not for under 16's (T.R. 3.3).

## 27.5 Special Regulations

- 27.5.1 In the case of (1) a false start, (2) a fall, (3) mechanical mishap to rollers or machines including punctures, before 100 metres have been covered by the leaders, a re-start shall be made in Championship races.
- 27.5.2 Organisers may at their discretion allow a re-start in other races in circumstances (2) and (3).
- 27.5.3 In cases of a false start, the riders must be recalled.
- 27.5.4 Notice must be given on entry form, prospectus and programme of these conditions.
- 27.5.5 Attendants may be allowed to hold riders and, in such cases, riders may select their own attendant.
- 27.5.6 Attendants must be neatly attired and, where the organiser requires a special costume, the attendant must comply with the request, the costume shall be provided by the organiser.
- 27.5.7 In events where riders are not held for the duration of a race, they must be released at 200 metres, a whistle signal being given at 100 metres and a second on 200 metres being reached by the leaders.

## 27 ROLLER RACING

27.1 Roller racing shall be exempt from permit fees and race levy (the insurance levy is still payable) and the necessity for competitors to be members of the Federation but, where roller racing is organised for members of the Federation, except on an informal basis, the provisions of T.R. 24 shall apply where appropriate.

27.2 The promoters shall cause the roller apparatus to be checked before the start of the racing to ensure it is safe and in proper working order.

### 27.3 Officials

27.3.1 The officials at a roller racing meeting shall consist of a Chief Commissaire, Starter, Timekeepers, Clerk of the Course, Gear Checker and Stewards as necessary.

27.3.2 The Chief Commissaire shall be the senior official at a Roller Racing meeting, and there must be a Chief Commissaire at every such meeting.

27.3.3 The Chief Commissaire and Timekeeper shall have a central position opposite the roller dials, and free from the audience.

27.3.4 The Starter when he sees the competitors are settled, shall ask 'Are you ready?' and if no reply to the contrary, effect the start by pistol or other pre-arranged signal. A bell shall be rung for the last lap or half lap as arranged, and the starter shall signal the finish of the race by pistol shot or as otherwise arranged when all the riders to be placed have completed the distance.

27.3.5 The Gear Checker shall check the gears and crank length of the machines to be used.

### 27.4 Gearing

27.4.1 In open competitions the maximum top gear permitted shall be such that the distance covered per crank revolution shall not exceed 8.26 metres, cranks must not be less than 165 millimetres.

27.4.2 The gear shall be checked against the distance covered by one revolution of the cranks at the

## APPENDIX 1

### UCI EQUIPMENT REGULATIONS

(Sections 1 and 2 introduced on 1st January 2000).

#### SECTION 1: GENERAL PROVISIONS

##### 1. Principles

- 1.3.001 Each licence-holder shall ensure that his equipment (bicycle with accessories and other devices fitted, headgear, apparel, etc.) does not, by virtue of its quality, materials or design, constitute any danger to himself or to others.
- 1.3.002 The UCI shall not be liable for any consequences deriving from the choice of the equipment used by licence-holders, nor for any defects it may have or its non-compliance.
- 1.3.003 In no case shall the fact that a rider has been able to take part in the competition give rise to liability on the part of the UCI; checks on equipment that may be carried out by the commissaires or by an agent or a body of the UCI being limited to the compliance of the overall external appearance for purely sporting purposes.

##### 2. Technical Innovations

- 1.3.004 Except in mountain bike racing, no technical innovation regarding anything used, worn or carried by any rider or license holder during a competition (bicycles, equipment mounted on them, accessories, helmets, clothing, means of communication, etc.) may be used until approved by the UCI executive bureau. Requests for approval shall be submitted to the UCI before 30th June of any year, accompanied by all necessary documentation. If accepted, the innovation will be permitted only as from 1st January of the following year.

Acceptance shall refer solely to the fact that the innovation will be acceptable from a sporting point of view.

There is no technical innovation in the sense of the present article if the innovation entirely falls within the specifications foreseen in the regulations.

- 1.3.005 If at the start of a competition or stage the Commissaires Panel considers that a rider arrives with a technical innovation not yet accepted by the UCI, it shall refuse to permit the rider to start with such an innovation.

In the event of use in competition the rider shall automatically be expelled from the competition or disqualified. There shall be no right to appeal against the decision of the Commissaire's Panel.

If this technical innovation is not noticed or sanctioned by the Commissaire's Panel, the UCI Disciplinary Commission shall order the disqualification. The UCI shall refer to the Disciplinary Commission, either automatically or at the request of all interested. The Disciplinary Commission will only apply sanctions after having received the opinion of the Equipment Commission.

In out of competition situations, the UCI shall decide whether an item should be considered a technical innovation and whether the procedure provided for in article 1.3.004 is to be followed.

#### SECTION 2 BICYCLES

##### Preamble

Bicycles shall comply with the spirit and principle of cycling as a sport. The spirit presupposes that cyclists compete in competitions on an equal footing. The principle asserts the primacy of man over machine.

##### 1. Principles

###### Definition

- 1.3.006 The bicycle is a vehicle with two wheels of equal diameter. The front wheel shall be steerable; the rear wheel shall be driven through a system comprising pedals and a chain.

###### Type

- 1.3.007 Bicycles and their accessories shall be of a type that is or could be sold for use by anyone practicing cycling as a sport. The use of equipment designed especially for the attainment of a particular performance (record or other) shall be not authorised.

###### Position

- 1.3.008 The rider shall normally assume a sitting position on the bicycle. This position requires that he be supported solely by the pedals, the saddle and the handlebars.

###### Steering

- 1.3.009 The bicycle should have handlebars which allows it to be ridden and manoeuvred in any circumstances and in complete safety.

###### Propulsion

- 1.3.010 The bicycle shall be propelled solely, through a chainset, by the legs (inferior muscular chain) moving in a circular movement, without electric or other assistance.

##### 2. Technical specifications

Except where stated to the contrary, the following technical specifications shall apply to bicycles used in Road, Track and Cyclo-Cross racing.

The specific characteristics of bicycles used in Mountain Bike, BMX, Trials, Indoor Cycling and cycling for riders with disabilities are set out in the part regulating the discipline in question.

- 1.3.011 a) Measurements (see diagram "Measurements (1)")

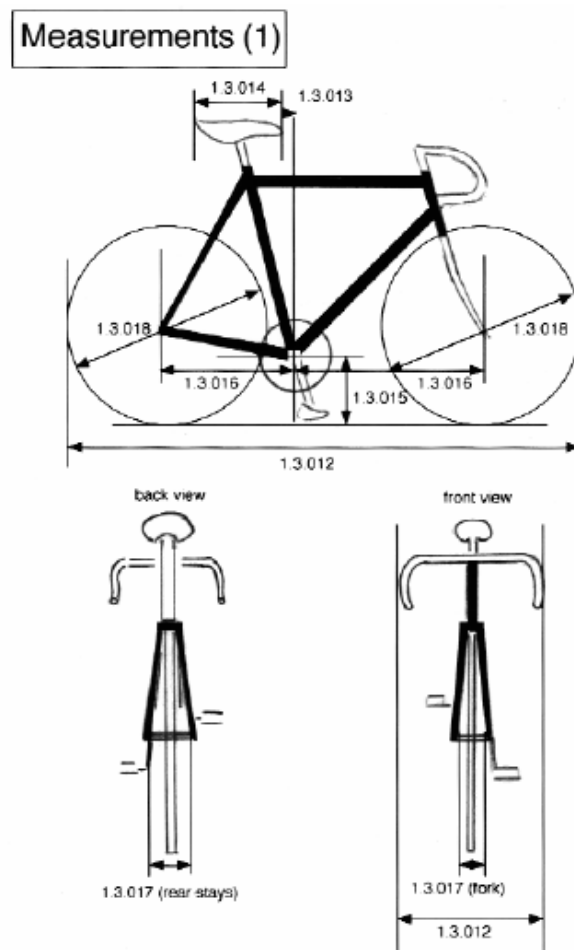

1.3.012 A bicycle shall not measure more than 185 cm in length and 50 cm in width overall.

A tandem shall not measure more than 270 cm in length and 50 cm in width overall.

1.3.013 The peak of the saddle shall be a minimum of 5 cm to the rear of a vertical plane passing through the bottom bracket spindle(1). This restriction shall not be applied to the bicycle ridden by a rider in a track sprint event, keirin, 500 metres or 1 kilometre time trials; however, in no circumstances shall the peak of the saddle extend in front of a vertical line passing through the bottom bracket spindle.

(1) The distances mentioned in footnote (1) to the articles 1.3.013 and 1.3.016 above may be reduced where that is necessary for morphological reasons. By morphological reasons should be understood everything to do with the size and limb-length of the rider.

Any rider who, for these reasons, considers that he needs to use a bicycle of lesser dimensions than those given shall inform the Commissaires Panel to that effect when presenting his licence. In that case, the Panel may conduct the following test. Using a plumb-line, they shall check to see whether, when pedalling, the point of the rider's knee when at its foremost position passes beyond a vertical line passing through the pedal spindle (see diagram "Measurements (2)").

### Measurements (2)

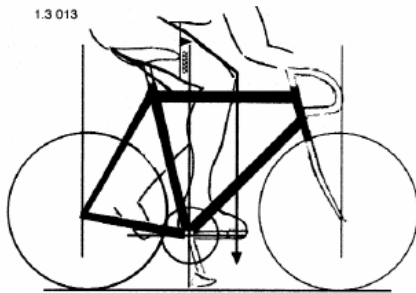

1.3.14 The saddle support shall be horizontal. The length of the saddle shall be 24 cm minimum and 30 cm maximum.

1.3.015 The distance between the bottom bracket spindle and the ground shall be between 24 cm minimum and 30 cm maximum.

1.3.016 The distance between the vertical passing through the lower bracket spindle and the front wheel spindle shall be between 54 cm minimum and 65 cm maximum.

The distance between the vertical passing through the bottom bracket spindle and the rear wheel spindle shall be between 35 cm minimum and 50 cm maximum.

1.3.017 The distance between the internal extremities of the front forks shall not exceed 10.5 cm; the distance between the internal extremities of the rear triangle shall not exceed 13.5 cm.

1.3.018 Wheels of the bicycle may vary in diameter between 70 cm maximum and 55 cm minimum, including the tyre. For the cyclo-cross bicycle the width of the tyre shall not exceed 35 mm and it may not incorporate any form of spike or stud.

For massed start competitions in the disciplines road and cyclo-cross only wheel designs granted prior approval by the UCI may be used. Wheels shall have at least 12 spokes; spokes can be round, flattened or oval, as far as no dimension of their sections exceeds 10 mm. In order to be granted approval wheels must have passed a rupture test as prescribed by the UCI in a laboratory approved by the UCI. The test results must show that the rupture characteristics obtained are compatible with those resulting from an impact

sustained during normal use of the wheel. The following criteria must be fulfilled:

- On impact, no element of the wheel may become detached and be expelled outwards.
- The rupture must not present any shattered or broken off elements, or any sharp or serrated surfaces that could harm the user, other riders and/or third parties.
- The rupture characteristics must not cause the hub to become separated from the rim in such a way that the wheel becomes detached from the forks.

Without prejudice to the tests imposed by the laws, regulations or customs, standard (traditional) wheels are exempted from the rupture test referred to above. A traditional wheel is deemed to be a wheel with at least 16 metal spokes; the spokes may be round, flat or oval, provided that no dimension of their cross sections exceeds 2.4 mm; the section of the rim must not exceed 2.5 cm on each side.

Notwithstanding this article, the choice and use of wheels remains subject to articles 1.3.001 to 1.3.003.

### b) Weight

1.3.019 The weight of the bicycle cannot be less to 6.8 kilograms.

### c) Configuration

1.3.020 For road competitions other than time trials and for cyclo-cross competitions, the frame of the bicycle shall be of a traditional pattern, i.e. built around a main triangle. It shall be constructed of straight or tapered tubular elements (which may be round, oval, flattened, teardrop shaped or otherwise in cross-section) such that the form of each element encloses a straight line. The elements of the frame shall be laid out such that the joining points shall follow the following pattern: the top tube (1) connects the top of the head tube (2) to the top of the seat tube (4); the seat tube (from which the seat post shall extend) shall connect to the bottom bracket shell; the down tube (3) shall connect the bottom bracket shell to the bottom of the head tube. The rear triangles shall be formed by the chain stays (6), the seat stays (5) and the seat tube (4) with the seat stays anchored to the seat tube at points falling within the limits laid down for the slope of the top tube.

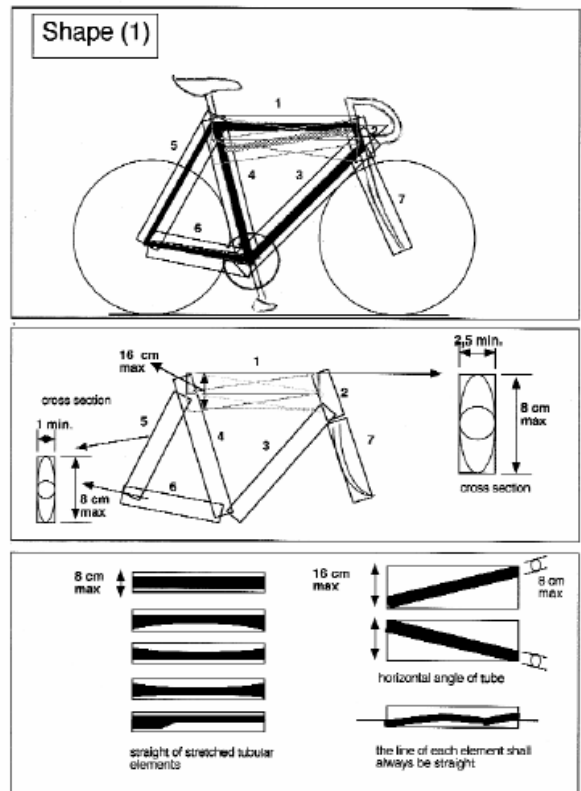

The maximum height of the elements shall be 8 cm and the minimum width 2.5 cm. The minimum width shall be reduced to 1 cm for the chain stays (6) and the seat stays (5). The minimum thickness of the elements of the front fork shall be 1cm; these may be straight or curved (7). (See diagram "Shape (1)").

The top tube may slope, provided that this element fits within an horizontal template defined by a maximum height of 16 cm and a minimum thickness of 2.5cm.

- 1.3.021 For road time trials and for track competitions, the elements of the bicycle frame may be tubular or solid, assembled or cast in a single piece in any form (including arches, cradles, beams or any other). These elements, including the bottom bracket shell, shall fit within a template of the "triangular form" defined in article 1.3.020. (See diagram "Shape (2)").

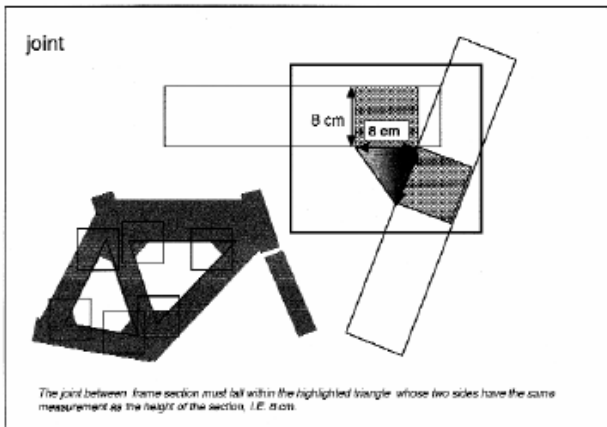
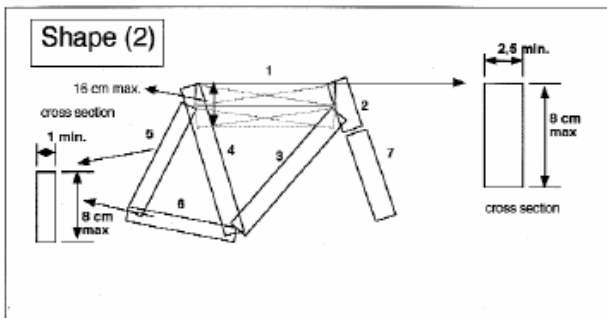

**d) Structure**

- 1.3.022 In competitions other than those covered by article 1.3.023, only the traditional type of handlebars (see diagram "structure 1") may be used. The point of support for the hands must be positioned in an area defined as follows: above, by the horizontal plane of the point of support of the saddle (B); below, by the horizontal line passing through the highest point of the two wheels (these being of equal diameter) (C); at the rear by the axis of the steerer tube (D) and at the front by a vertical line passing through the front wheel spindle with a 5 cm tolerance (see diagram "Structure (1A)"). The distance referred to in point (A) is not applicable to the bicycle of a rider who takes part in a sprint, keirin or Olympic sprint race, but must not exceed 10 cm in relation to the vertical line passing through the front wheel spindle.

The brake controls attached to the handlebars shall consist of two supports with levers. It must be possible to operate the brakes by pulling on the levers with the hands on the lever supports. Any extension to or reconfiguration of the supports to enable an alternative use is prohibited. A combined system of brake and gear controls is authorised.

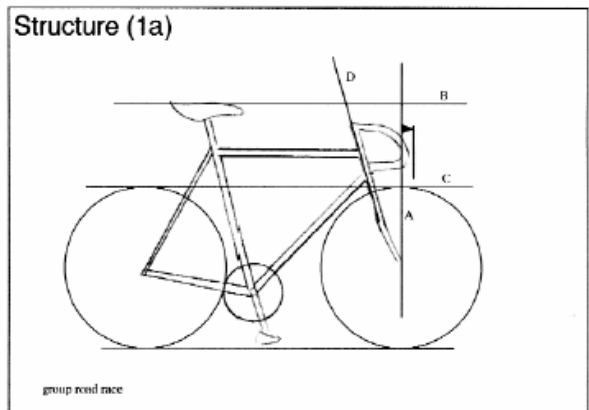

- 1.3.023 For road time trial competitions and for the following track competitions: individual and team pursuits, kilometre and 500 m time trials, an extension may be added to the steering system. The distance between the vertical line passing through the bottom bracket axle and the extremity of the handlebar may not exceed 75 cm, with the other limits set in article 1.3.022 (B,C,D) remaining unchanged. A support for the elbows or forearms is permitted (see diagram "Structure (1B)").

For road time trial competitions, controls or levers fixed to the handlebar extension may extend beyond the 75 cm limit as long as they do not constitute a change of use, particularly that of providing an alternative hand position beyond the 75 cm mark.

For the track and road competitions covered by the first paragraph, the distance of 75 cm may be increased to 80 cm to the extent that this is required for morphological reasons; "morphological reasons" should be taken as meaning anything regarding the size or length of the rider's body parts. A rider who, for this reason, considers that he needs to make use of a distance between 75 and 80 cm must inform the Commissaires' Panel at the moment that he presents his licence. In such cases the Commissaires' Panel may carry out the following test: ensuring that the angle between the forearm and upper arm does not exceed 120° when the rider is in a racing position.

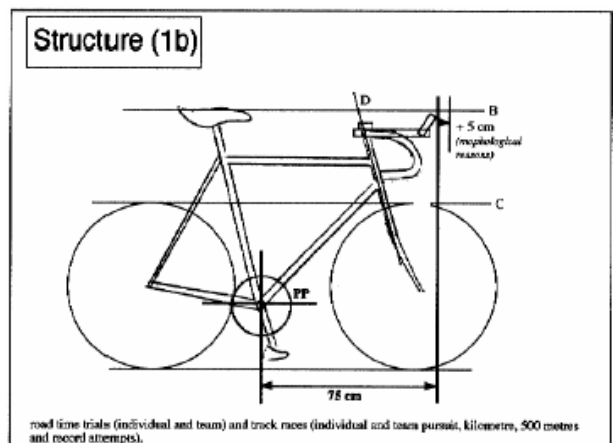

- 1.3.024 Any device, added or blended into the structure, that is destined to decrease, or which has the effect of decreasing, resistance to air penetration or artificially to accelerate propulsion, such as a protective screen, fuselage form of fairing or the like, shall be prohibited.

**Structure (2)**

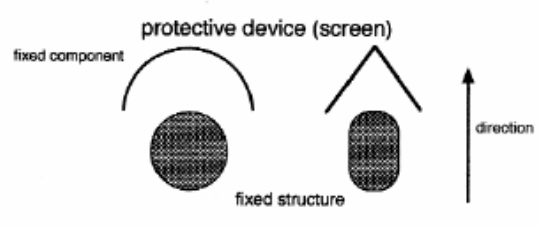

A protective screen shall be defined as a fixed component that serves as a windscreen or windbreak designed to protect another fixed element of the bicycle in order to reduce its wind resistance.

**Form**

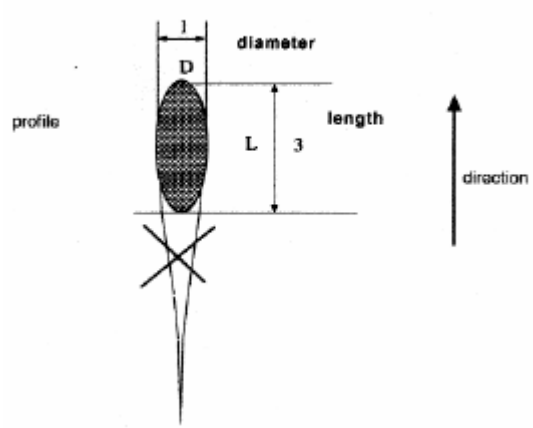

A fuselage form shall be defined as an extension or streamlining of a section. This shall be tolerated as long as the ratio between the length L and the diameter D does not exceed 3.

**Structure (3)**

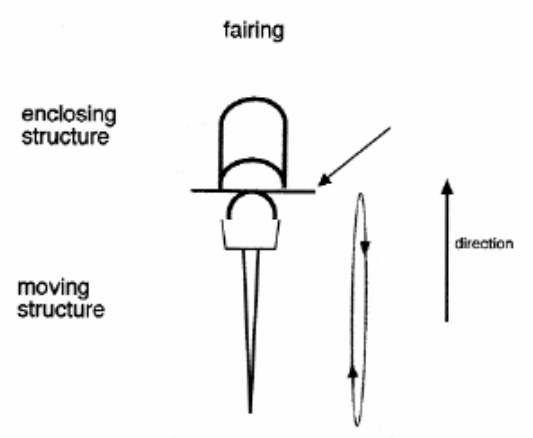

practical way of confirming the existence of fitting on a moving part such as a wheel : it should be possible to pass a rigid card (like a credit card) between the fixed structure and the moving part.

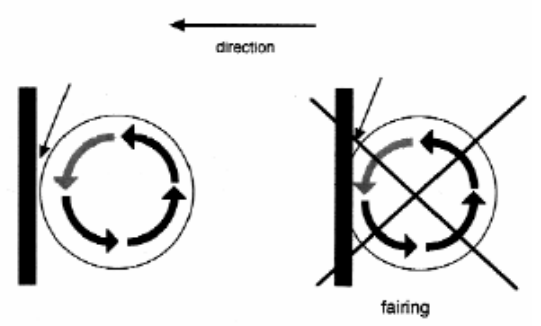

A fairing shall be defined as the use or adaptation of a component of the bicycle in such a fashion that it encloses a moving part of the bicycle such as the wheels or the chainset. Therefore it should be possible to pass a rigid card (like a credit card) between the fixed structure and the moving part.

1.3.025 Freewheels, multiple gears and brakes are not permitted for use on the track during competition or training. Disc brakes are forbidden in cyclo-cross training and competition.

## **APPENDIX 2**

### **ROAD RACE LEAGUES**

As soon as possible after 30th September, when details of all open events have been fixed, clubs affiliated to a league will select, from the race free days, a date(s) for their league promotion(s), the course(s) to be used and category(ies) to be accepted.

League races shall be on previously approved courses

By 1st February, or at least two months prior to the first event, whichever is the latter, the league should

apply to its Region for permits for all the proposed race dates en bloc, submitting the relevant permit application forms, event registration forms, event insurance and permit fees for each day of racing.

Clubs will appoint a league representative who will handle all registrations and entries and to whom all results will be sent. They shall also appoint an organiser who will be responsible for 'on the day' aspects of their own promotion who shall be a full member of the Federation.

All riders must be registered with the league. The form used must contain the disclaimer that heads the normal signing on sheet as well as room for the rider to complete his usual personal details.

A calendar of events must be issued to each registered rider. This calendar must include dates of each race, courses, times of start, race headquarters, permitted categories, on the day organisers phone number. This document must also carry a statement that each event listed will be run under the Technical Regulations of the British Cycling Federation. The name and address of the League Co-ordinator shall also appear on that document. This paper will replace the programme/start list to be sent to the constabulary and effected Regions. No other notification will need to be sent to riders.

The league administration will complete all permit application forms and will liaise with the appropriate Region as regards the appointment of key officials and police authorisations.

A league will be responsible for the collection of entries, making out and despatch of signing on sheets, consolidation and publication of results by what ever means it feels best suits their circumstances. It will forward levies to the relevant Region Treasurer at least once per calendar month, pay for changing accommodation, first aid and other race expenses as agreed within the individual league regulations. Payment of prizes will take place after the last league event has taken place.

Recommendations- Each League should have a 'Hotline' for up to date race information and a back up stock or supply of all race aids necessary for the safe promotion of it's events.

## **APPENDIX 3**

### **REGULATIONS FOR THE ORGANISATION OF RELIABILITY RIDES**

- 1. General**  
Reliability rides are not races, and shall be organised simply to require that each entrant must ride over a specified distance within an agreed time.  
The rides may be organised to provide for entrants to ride alone or in groups.
- 2. Entries**  
A closing date shall be set for entries to enable the organiser to ensure that riders are placed in manageable groups.
- 3. Size of groups**  
In the case of entrants riding in groups, no one group should at any time consist of more than twenty riders.
- 4. Conduct of groups**  
All riders in a group must ride in an orderly manner in accordance with the law relating to road travel, not more than two abreast, and extend all reasonable courtesy to other road users.

The organiser must appoint travelling controllers to ensure that these regulations are being obeyed. It shall be the duty of a controller to report to the event organiser any rider who offends against good road conduct or any of these regulations, giving details of the circumstances of the offence. The organiser shall then take such action as he thinks necessary, e.g., disqualification, reporting the rider(s) concerned to the appropriate club(s), refusing entry to future similar events and publication thereof on the finishing sheet, etc.

- 5. Intervals between riders**  
Where riders are started individually the interval between their despatch shall not be less than one minute.  
Where riders are started in groups the interval between each group shall not be less than five minutes.
- 6. Route**  
The route of a reliability ride shall be so planned that it will necessitate all-round riding ability and not sheer speed. The roads selected shall be such that group-riding on them will cause the minimum of inconvenience to other road users.
- 7. Condition of cycles and equipment**  
Participants will be responsible for the roadworthiness of their own cycle. It is recommended that mudguards be used for the comfort of the participant and other riders.
- 8. Maximum speed**  
No reliability ride shall be promoted which requires the participants to maintain an average riding speed of more than 18 m.p.h. 'Average riding speed' means the average speed when actually riding and in calculating it all periods allowed for meals and reporting must be deducted from the total time allowed for the scheduled distance.  
Controlling points must be positioned on the route to ensure that the average riding speed is not being exceeded. The average distance between controls shall not exceed 30 miles.
- 9. Publication of 'Result'**  
The only "result" that shall be issued shall be a list of riders who have completed the route within the specified time. Organisers must not publish any finishing times or indicate the order in which riders finished.
- 10. Compliance with the regulations**  
Controllers should be given authority to ensure these regulations are enforced.  
Failure to comply with these regulations may lead to the organiser and/or promoting club being charged with conduct prejudicial to the good order of the sport.

## **APPENDIX 4**

### **REGULATIONS FOR BC CYCLOSPORTIVE (CYCLING FOR ALL) EVENTS**

- 1** These Events will be known as Cyclo sportive events. All paperwork produced will state 'Under British Cycling Cyclo-Sportive Regulations'.
- 2** Every Event will carry the BCF Event Insurance (on payment of the appropriate fee by the organiser) which will cover the club, the promoter, other officers of the club, the event officials and all participants for the duration of the event against any claims from a third party.
- 3** Participants will be responsible for the roadworthiness of their own cycle.
- 4** The organiser shall complete Everyday Cycling Event registration and Risk Assessment forms and forward to HQ and Police authorities whose area the event

passes. It is also advisable to inform other relevant local authorities whose area the event passes such as highways dept.

- 5 The organiser will ensure that the course is checked within 48 hours prior to the event and any danger points advised to each participant on the day.
- 6 The organiser shall wherever possible select a route that is low in traffic volumes and away from major towns. When choosing a suitable route consideration should be given to finding a hill early in the event to alleviate the possibility of bunches forming.
- 7 Route markers will be used to identify the route to be taken. However it is the responsibility of each participant to take the correct course.
- 8 No accompanying vehicles are allowed to follow riders. Any participant failing to observe this regulation will be withdrawn from the event. The provision of a broom wagon will be appropriate to the number of participants taking part in the event.
- 9 There will be no list published which indicates a finishing position or time. An alphabetical list of finishers and times will be published.
- 10 The wearing of Hard Shell Style Helmets shall be compulsory for riders under the age of eighteen. Senior riders are encouraged to do the same.
- 11 All participants under the age of eighteen shall have had a consent form completed by their parent/guardian. A parent or guardian must accompany riders under the age of sixteen.
- 12 It is advised that all riders must carry a form of identification showing their name, address and contact details of person to be advised in the eventuality of an accident. It is also advised that all participants carry enough food, drink, money, mobile phone, spare inner tubes and a working pump, as well as extra clothing to complete the ride being undertaken, taking into account the route and possible adverse weather conditions.
- 13 The organiser has the option to take entries on the line as well in advance. An increase in the entry fee may be charged for this privilege at the discretion of the organiser.
- 14 The organiser must supply refreshment services to participants at least every 40 miles. It is also advisable to provide mechanical support services at these points on the course.
- 15 The organisation shall provide adequate toilet facilities for the number of participants expected.
- 16 Any complaints with regard to the event must be made to the organiser within 48 hours of the promotion.
- 17 Promoters are given authority to ensure that the above regulations in respect of rider participation are enforced. In cases where the organiser fails to comply with any of the above regulations he and/or the promoting club may be charged with conduct prejudicial to the good order of the sport.
- 18 The use of triathlon handlebars is discouraged in such events. However, where riders do have them fitted they are not to be used when riding in a group. This statement should be printed on literature for participants taking part in the event.
- 19 An adequate number of first aiders will be provided and will be stationed at strategic points as necessary in accordance with the risk assessment and appropriate to the number of riders entered and the length and layout of the course. It is advisable to alert the local Accident and Emergency dept that the event is taking place.

## **APPENDIX 5**

### **REGULATIONS FOR 'COME AND TRY CYCLING' SESSIONS**

#### **Definition of a 'Come and Try Cycling' Session.**

These are activities run in a controlled environment, particularly aimed at novice riders, in an area closed to all vehicular traffic. They may take the form of a Cycling Skills Test using various obstacles, tests using static cycles or 'mini' races.

#### **General Regulations.**

##### **1 Cycling Skills Tests**

No obstacle over which a rider may ride may be of greater height than 30cm.

A minimum of two responsible adults shall be present at all times once the Skill Test Course has been set up.

Suitable Protective Headgear must be worn by all participants and cycles, when loaned by the organiser, must be in full working order. Care should be taken to ensure that loose clothing, and untied shoe laces will not catch up in the cycle to be used.

In situations such as shows and other public attractions, the area to be used must be fully marked off and entrance to the Skills Test area fully controlled.

The named organiser must be a full member of the Federation.

##### **2 Static Cycle Come and Try**

*(i.e. Rollers, Turbo Trainers, Computrainers, Kingcycles etc.)*

Tests need to be made as aerobic as possible, particularly with very unfit participants over 30 years of age.

Tests to be only conducted for under 40's except in the case of trained competitive cyclists.

Tests must be conducted in the presence of an BCF Qualified Coach and at least one other responsible adult.

All participants are required to sign a sheet carrying the following declaration :

*'I UNDERSTAND AND AGREE THAT I PARTICIPATE IN THIS PHYSICALLY DEMANDING TEST AT MY OWN RISK. I KNOW OF NO DISABILITY OR MEDICAL CONDITION, PHYSICAL OR MENTAL, WHICH COULD BE AFFECTED BY MY TAKING PART IN THIS ACTIVITY'.*

The area within which these tests are conducted must be managed in such a way as to prevent access to the rig and rider upon it by those not directly involved with the testing of that rider.

Care should be taken to ensure that loose clothing and untied shoe laces will not catch in the cycle to be used.

The organiser must be a gold or silver member of the Federation.

##### **3 Mini Races**

It is preferred that 'speed' competition between novice riders be conducted on grass on a time trial basis. However group races, handicap or scratch are permitted under strictly controlled environments.

Suitable Protective Headgear must be worn by all participants and cycles must be in full working order. The responsibility for the roadworthy and safe condition of any bicycle used is that of the competitor, or the parent or guardian should the competitor be under 19 years of age. Care should be taken to ensure that loose clothing and untied shoe laces will not catch in the cycle to be used.

Any course to be used must be made as safe as possible with plenty of space and no sharp corners or highly technical sections. Access to the course must be restricted to ensure that only those participating or controlling the event can enter the competition area.

The named organiser must be a full member of the Federation.

All participants are required to complete their required details on the standard BCF signing on sheet.

All under 18's are also required to produce a completed parental consent form.

**Note** Supplies of both forms or details of the wording required can be obtained from BCF Headquarters on request.

## APPENDIX 6

### BRITISH TIME TRIAL CHAMPIONSHIPS

1 A joint promotion between BC & Cycling Time Trials under BC/UCI Regulations.

2 All competitors must have been continuously resident in Great Britain for the two previous years or have proven British nationality. Such persons must be either a member of an affiliated Cycling Time Trials/SCU Club/Team **or** a Silver or Gold member of BC. Non BC members who are members of CTT affiliated clubs wishing to ride the Championship will be given the appropriate level of BC membership free of charge.

3 Championships-  
 Men (40-50km)  
 Espoir (30-40km)  
 Junior Men (20-30km)  
 Masters (30-40km)  
 Women (20-30km)  
 Espoir Women (20-30km)  
 Junior Women (20-30km)  
 Disability Category (20-30km)

Juniors must be 14 years old on 1<sup>st</sup> January 1998 and no older than 18 on 31<sup>st</sup> December 2008.

The Masters Championships shall be in five-year age bands. For 2008 these shall be as follows:

Master A	30 – 34	born in 1974, 1975, 1975/6 1977 or 1978
Master B	35 – 39	born in 1969, 1970, 1971, 1972 or 1973
Master C	40 – 44	born in 1964, 1965, 1966, 1967 or 1968
Master D	45 – 49	born in 1959, 1960, 1961, 1962 or 1963
Master E	50 – 54	born in 1954, 1955, 1956, 1957 or 1958
Master F	55 – 59	born in 1949, 1950, 1951, 1952 or 1953
Master G	60 – 64	born in 1944, 1945, 1946, 1947 or 1948
Master H	65 – 69	born in 1939, 1940, 1941, 1942 or 1943
Master I	70 +	born in 1938 or earlier

4 Master and Espoir riders may opt to ride in the Men's Championship.

5 Each lap shall be approximately 16km in length and undulating in nature with three laps to be completed by the winner of the Men's event at a speed of just over 50kph.

6 A Special entry form and declaration shall apply with British Cycling insurance cover. Entries will close 28 days prior to the event.

7 The wearing of protective hardshell helmets is compulsory for all competitors.

8 Overall control of the event on the day to be overseen by a UCI Chief Commissaire as appointed by BC.

9 Following service vehicles shall be restricted to those riders as agreed by the organisers. Each such vehicle should have room to carry a Commissaire/Observer.

10 A maximum of the top ten seeded riders shall be the last to start in each Championship, with at least a two-minute gap between the start times allocated to each such rider.

11 In all categories except Masters, machines to be used shall comply with current UCI Technical Regulations. Juniors shall be restricted to a gear of 7.93 metres.

12 The colours of clothing worn by competitors shall be at their discretion, except that only those commercial endorsements previously registered with Cycling Time Trials or BC may be worn. Where a rider meets the requirements of Regulation 2), above but holds a competition licence of a foreign UCI affiliated Federation, he/she may ride in the name, colours and sponsors of that team as shown on such a licence.

#### 13 Men, Women, Espoirs & Juniors:

Where there are eight or more entrants in any category specific medals (1st, 2nd, 3rd) to be awarded along with standard national champion's jersey showing the logos of both organisations. Where there are six/seven entrants medals shall only be presented to the first two places along with a jersey. Where there are less than six, but more than two entrants a gold medal will only be awarded to the winner along with a jersey.

#### Disability, Masters & Junior Women:

Where there are five or more entrants in any category specific medals (1st, 2nd, 3rd) to be awarded along with standard national champion's jersey showing the logos of both organisations. Where there are four entrants medals shall only be presented to the first two places along with a jersey. Where there are three entrants a gold medal will only be awarded to the winner along with a jersey.

14 The notifications as required under the Cycle Racing on the Highways Act shall be managed by the relevant Cycling Time Trials District.

15 The entry fee shall be £12.00 with the levy income (£5.00 per entrant) shared equally between BC and Cycling Time Trials after the purchase and engraving costs of the medals.

16 All local regulations relevant to the use of the course shall be adhered to and printed on the startsheet.

## APPENDIX 7 GEAR TABLES

### Metric Gear Tables

Standard Sprint Rim with 18mm low profile tubular and standard standard 700c rim with racing tyre slick H.P. tyre															
SPROCKET SIZE															
	12	13	14	15	16	17	18	19	20	21	22	23	24	25	26
40	7.01	6.47	6.01	5.61	5.26	4.95	4.67	4.43	4.21	4.01	3.82	3.66	3.51	3.37	3.24
41	7.19	6.63	6.16	5.75	5.39	5.07	4.79	4.54	4.31	4.11	3.92	3.75	3.59	3.45	3.32
42	7.36	6.80	6.31	5.89	5.52	5.20	4.91	4.65	4.42	4.21	4.02	3.84	3.68	3.53	3.40
43	7.54	6.96	6.46	6.03	5.65	5.32	5.02	4.76	4.52	4.31	4.11	3.93	3.77	3.62	3.48
44	7.71	7.12	6.61	6.17	5.78	5.44	5.14	4.87	4.63	4.41	4.21	4.02	3.86	3.70	3.56
45	7.89	7.28	6.76	6.31	5.92	5.57	5.26	4.98	4.73	4.51	4.30	4.12	3.94	3.79	3.64
46	8.06	7.44	6.91	6.45	6.05	5.69	5.38	5.09	4.84	4.61	4.40	4.21	4.03	3.87	3.72
47	8.24	7.60	7.06	6.59	6.18	5.82	5.49	5.20	4.94	4.71	4.49	4.30	4.12	3.95	3.80
48	8.41	7.77	7.21	6.73	6.31	5.94	5.61	5.31	5.05	4.81	4.59	4.39	4.21	4.04	3.88
49	8.59	7.93	7.36	6.87	6.44	6.06	5.73	5.42	5.15	4.91	4.68	4.48	4.29	4.12	3.96
50	8.76	8.09	7.51	7.01	6.57	6.19	5.84	5.54	5.26	5.01	4.78	4.57	4.38	4.21	4.04
51	8.94	8.25	7.66	7.15	6.70	6.31	5.96	5.65	5.36	5.11	4.88	4.66	4.47	4.29	4.13
52	9.11	8.41	7.81	7.29	6.84	6.43	6.08	5.76	5.47	5.21	4.97	4.76	4.56	4.37	4.21
53	9.29	8.57	7.96	7.43	6.97	6.56	6.19	5.87	5.57	5.31	5.07	4.85	4.64	4.46	4.29
54	9.46	8.74	8.11	7.57	7.10	6.68	6.31	5.98	5.68	5.41	5.16	4.94	4.73	4.54	4.37
55	9.64	8.90	8.26	7.71	7.23	6.80	6.43	6.09	5.78	5.51	5.26	5.03	4.82	4.63	4.45
56	9.82	9.06	8.41	7.85	7.36	6.93	6.54	6.20	5.89	5.61	5.35	5.12	4.91	4.71	4.53

Standard Sprint Rim with normal road tubular tyre															
SPROCKET SIZE															
	12	13	14	15	16	17	18	19	20	21	22	23	24	25	26
40	7.12	6.57	6.10	5.69	5.34	5.02	4.75	4.50	4.27	4.07	3.88	3.71	3.56	3.42	3.29
41	7.30	6.74	6.25	5.84	5.47	5.15	4.86	4.61	4.38	4.17	3.98	3.81	3.65	3.50	3.37
42	7.47	6.90	6.41	5.98	5.61	5.28	4.98	4.72	4.48	4.27	4.08	3.90	3.74	3.59	3.45
43	7.65	7.06	6.56	6.12	5.74	5.40	5.10	4.83	4.59	4.37	4.17	3.99	3.83	3.67	3.53
44	7.83	7.23	6.71	6.26	5.87	5.53	5.22	4.95	4.70	4.47	4.27	4.09	3.92	3.76	3.61
45	8.01	7.39	6.86	6.41	6.01	5.65	5.34	5.06	4.80	4.58	4.37	4.18	4.00	3.84	3.70
46	8.19	7.56	7.02	6.55	6.14	5.78	5.46	5.17	4.91	4.68	4.47	4.27	4.09	3.93	3.78
47	8.36	7.72	7.17	6.69	6.27	5.90	5.58	5.28	5.02	4.78	4.56	4.36	4.18	4.01	3.86
48	8.54	7.89	7.32	6.83	6.41	6.03	5.69	5.40	5.13	4.88	4.66	4.46	4.27	4.10	3.94
49	8.72	8.05	7.47	6.98	6.54	6.16	5.81	5.51	5.23	4.98	4.76	4.55	4.36	4.19	4.02
50	8.90	8.21	7.63	7.12	6.67	6.28	5.93	5.62	5.34	5.08	4.85	4.64	4.45	4.27	4.11
51	9.08	8.38	7.78	7.26	6.81	6.41	6.05	5.73	5.45	5.19	4.95	4.74	4.54	4.36	4.19
52	9.25	8.54	7.93	7.40	6.94	6.53	6.17	5.84	5.55	5.29	5.05	4.83	4.63	4.44	4.27
53	9.43	8.71	8.08	7.55	7.07	6.66	6.29	5.96	5.66	5.39	5.14	4.92	4.72	4.53	4.35
54	9.61	8.87	8.24	7.69	7.21	6.78	6.41	6.07	5.77	5.49	5.24	5.01	4.80	4.61	4.44
55	9.79	9.03	8.39	7.83	7.34	6.91	6.53	6.18	5.87	5.59	5.34	5.11	4.89	4.70	4.52
56	9.97	9.20	8.54	7.97	7.47	7.03	6.64	6.29	5.98	5.69	5.44	5.20	4.98	4.78	4.60

### Imperial Gear Table

	SPROCKET SIZE																			
	12	13	14	15	16	17	18	19	20	21	22	23	24	25	26	27	28	29	30	
57	128.3	118.4	110.0	102.6	96.2	90.5	85.5	81.0	77.0	73.3	70.0	66.9	64.1	61.6	59.2	57.0	55.0	53.1	51.3	
56	126.0	116.3	108.0	100.8	94.5	89.0	84.0	79.6	75.6	72.0	68.7	65.8	63.0	60.5	58.2	56.0	54.0	52.1	50.4	
55	123.8	114.3	106.1	99.0	92.8	87.4	82.5	78.2	74.3	70.7	67.5	64.6	61.9	59.4	57.1	55.0	53.0	51.2	49.5	
54	121.5	112.2	104.2	97.2	91.1	85.8	81.0	76.8	72.9	69.4	66.3	63.4	60.8	58.3	56.1	54.0	52.1	50.3	48.6	
53	119.3	110.1	102.2	95.4	89.5	84.2	79.5	75.3	71.6	68.2	65.1	62.2	59.6	57.3	55.0	53.0	51.1	49.4	47.7	
52	117.0	108.0	100.3	93.6	87.8	82.6	78.0	73.9	70.2	66.9	63.8	61.1	58.5	56.2	54.0	52.0	50.2	48.4	46.8	
51	114.8	105.9	98.4	91.8	86.1	81.0	76.5	72.5	68.9	65.6	62.6	59.9	57.4	55.1	53.0	51.0	49.2	47.5	45.9	
50	112.5	103.9	96.4	90.0	84.4	79.4	75.0	71.1	67.5	64.3	61.4	58.7	56.3	54.0	51.9	50.0	48.2	46.6	45.0	
49	110.3	101.8	94.5	88.2	82.7	77.8	73.5	69.6	66.2	63.0	60.1	57.5	55.1	52.9	50.9	49.0	47.3	45.6	44.1	
48	108.0	99.7	92.6	86.4	81.0	76.3	72.0	68.2	64.8	61.7	58.9	56.4	54.0	51.9	49.9	48.0	46.3	44.7	43.2	
47	105.8	97.6	90.7	84.6	79.3	74.7	70.5	66.8	63.5	60.4	57.7	55.2	52.9	50.8	48.8	47.0	45.3	43.8	42.3	
46	103.5	95.6	88.7	82.8	77.6	73.1	69.0	65.4	62.1	59.2	56.5	54.0	51.8	49.7	47.8	46.0	44.4	42.8	41.4	
45	101.3	93.5	86.8	81.0	76.0	71.5	67.5	64.0	60.8	57.9	55.2	52.8	50.6	48.6	46.7	45.0	43.4	41.9	40.5	
44	99.0	91.4	84.9	79.2	74.3	69.9	66.0	62.5	59.4	56.6	54.0	51.7	49.5	47.5	45.7	44.0	42.4	41.0	39.6	
43	96.8	89.3	82.9	77.4	72.6	68.3	64.5	61.1	58.1	55.3	52.8	50.5	48.4	46.4	44.7	43.0	41.5	40.0	38.7	
42	94.5	87.2	81.0	75.6	70.9	66.7	63.0	59.7	56.7	54.0	51.6	49.3	47.3	45.4	43.6	42.0	40.5	39.1	37.8	
41	92.3	85.2	79.1	73.8	69.2	65.1	61.5	58.3	55.4	52.7	50.3	48.1	46.1	44.3	42.6	41.0	39.5	38.2	36.9	
40	90.0	83.1	77.2	72.0	67.5	63.5	60.0	56.9	54.0	51.4	49.1	47.0	45.0	43.2	41.5	40.0	38.6	37.2	36.0	
39	87.8	81.0	75.2	70.2	65.8	62.0	58.5	55.4	52.7	50.2	47.9	45.8	43.9	42.1	40.5	39.0	37.6	36.3	35.1	
38	85.5	78.9	73.3	68.4	64.1	60.4	57.0	54.0	51.3	48.9	46.6	44.6	42.8	41.0	39.5	38.0	36.7	35.4	34.2	
37	83.3	76.9	71.4	66.6	62.5	58.8	55.5	52.6	50.0	47.6	45.4	43.4	41.6	40.0	38.4	37.0	35.7	34.5	33.3	
36	81.0	74.8	69.4	64.8	60.8	57.2	54.0	51.2	48.6	46.3	44.2	42.3	40.5	38.9	37.4	36.0	34.7	33.5	32.4	
35	78.8	72.7	67.5	63.0	59.1	55.6	52.5	49.7	47.3	45.0	43.0	41.1	39.4	37.8	36.4	35.0	33.8	32.6	31.5	

Measurement in inches =  $\frac{\text{No. teeth on chainring} \times \text{diameter back wheel (27")}}{\text{No. teeth on sprocket}}$